Modular Logic Controllers for Machining Systems: Formal Representation and Analysis using Petri Nets



Dawn Tilbury

**Mechanical Engineering and Applied Mechanics
University of Michigan**

Acknowledgments

- **Joint work with Euisu Park and Pramod Khargonekar of University of Michigan**
- **Funding provided by NSF/ERC for Reconfigurable Machining Systems at UM**
- **Industrial partners from Lamb Technicon for motivation, examples, and feedback**

Outline

- **Motivation: Logic control problem for high-volume machining systems**
- **Background**
- **Automatic cycle logic control**
- **Multi-mode logic control**
- **Implementation and future work**

High-volume machining systems

- **Cycle time determined by projected demand**
 - 500,000 parts/year → one part every 20 sec.
 - One operation per station
- **Dedicated transfer machine:**
 - Fixed material handling, part flow
 - Highly accurate and repeatable operations
 - 10-12 stations, buffer at beginning/end
 - 5,000-10,000 I/O points (sensors/actuators)
 - 10-20 transfer machines per transfer line



Control of machining systems

- **Continuous variable control (servo, CNC)**
 - Positioning, feed for metal removal, fixturing, and transfer operations: mainly SISO loops
- **Discrete-variable (Logic) control (PLC)**
 - Sequencing of operations
 - Coordination and synchronization of stations
 - User interface (pushbuttons & display)
 - Fault diagnosis and fault handling
 - Safety: gates and interlocks
 - Machine services: coolant, lubrication

Logic control problems

- **Control software is 50%** of machining system development time and cost
 - Often written in low-level language (ladder)
 - Specification for automatic cycle: timing bar chart, but only requires 10% of control code
 - No specification for alternate control modes, error handling, diagnostics
- **No formal verification before implementation**
- **Long testing and debugging cycles result**

Industry trends

- **Faster time to market for new products**
 - Must reduce system development time
- **Shorter product lifecycles**
 - Need to change manufacturing systems to produce new products
- **Increased quality**
 - Integrate new technologies into existing manufacturing systems

Reconfigurable machining systems

- **Modular:** easy assembly, potential reuse
- **Upgradable:** new technology integration
- **Convertible:** quick changeover to new part

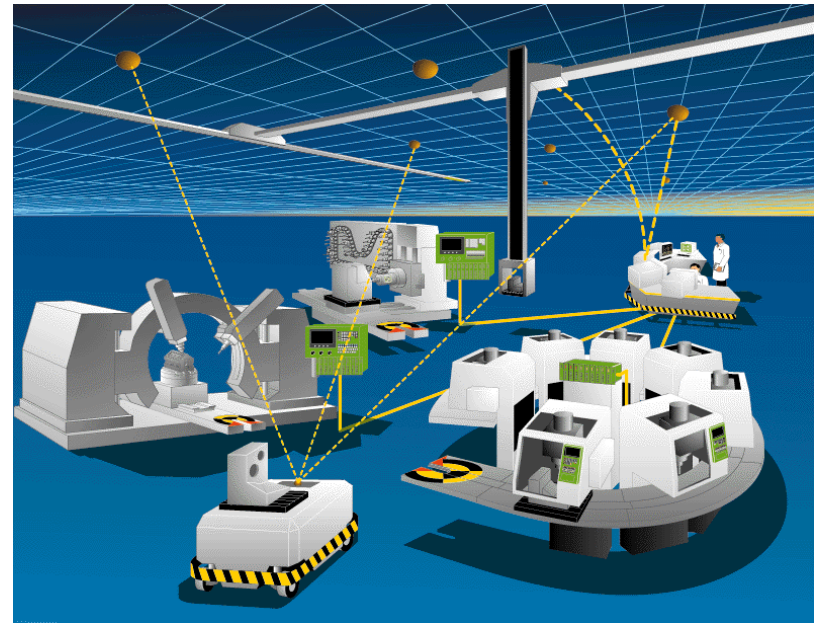
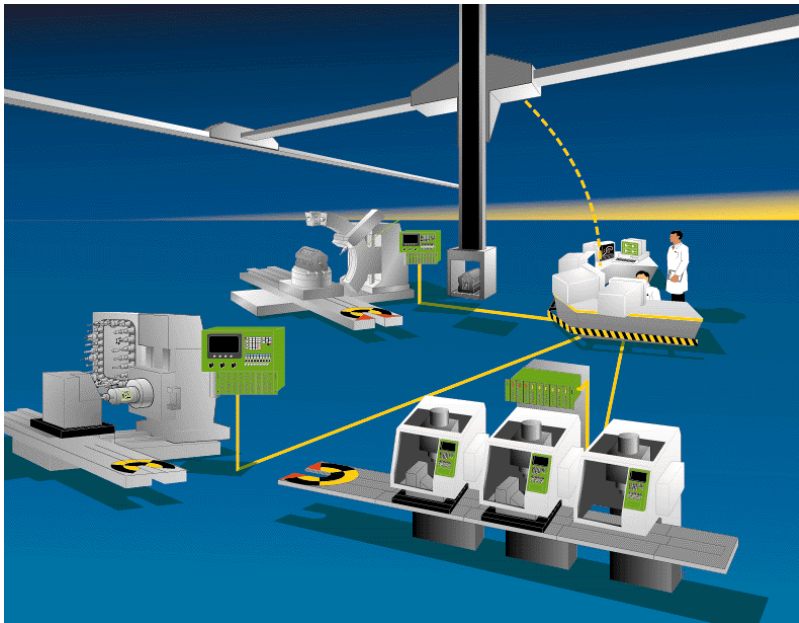

Logic control challenges in RMS

- **Modular structure**
 - Same granularity as machine modules
 - Ease of configuration/reconfiguration
- **Mathematical basis**
 - Enable formal verification of correctness
 - High-level abstraction for ease of understanding control system functionality
- **Industrial implementation**
 - Realistic complexity (thousands of events)
 - Target system: PLC or PC code generation

Outline

- **Motivation: Logic control problem for high-volume machining systems**
- **Background**
 - **Transfer lines and Petri nets**
- **Automatic cycle logic control**
- **Multi-mode logic control**
- **Implementation and future work**

Transfer line example

- Modular, standardized machining systems
- Each station self-contained with controls
- Coordination through transfer bar

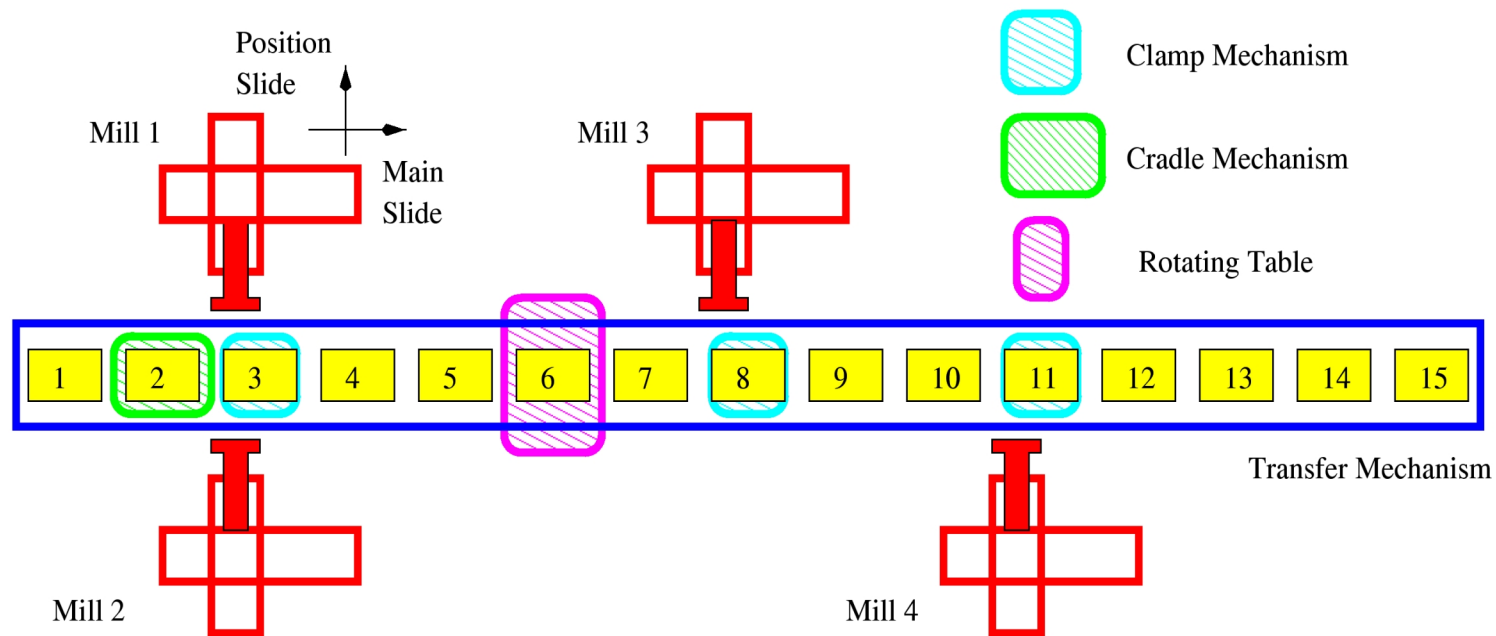

Control specification

Timing bar chart specifies auto mode

- Developed by machine designers
- Operation sequence
- Causal dependencies
- Home operation
 - Mechanical stability
- Hydraulics
- Cycle time

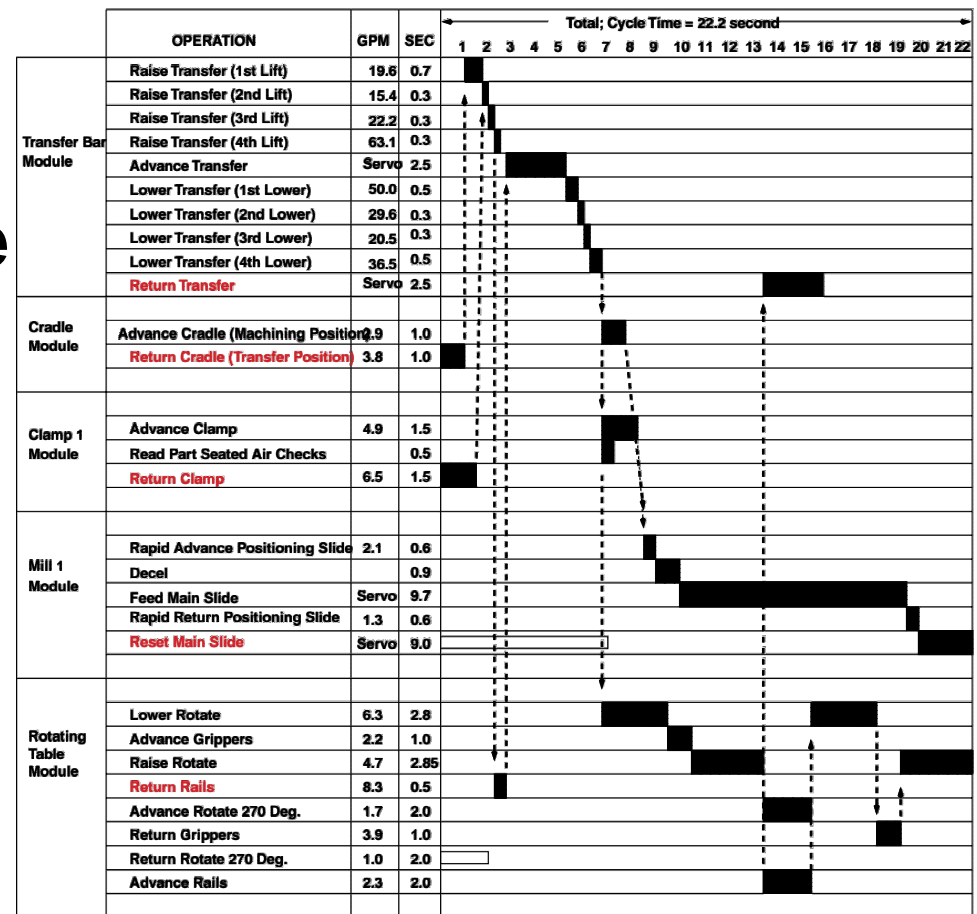

Logic control block diagram

- **Inputs: sensors and operator commands**
- **Outputs: servo or hydraulic devices**

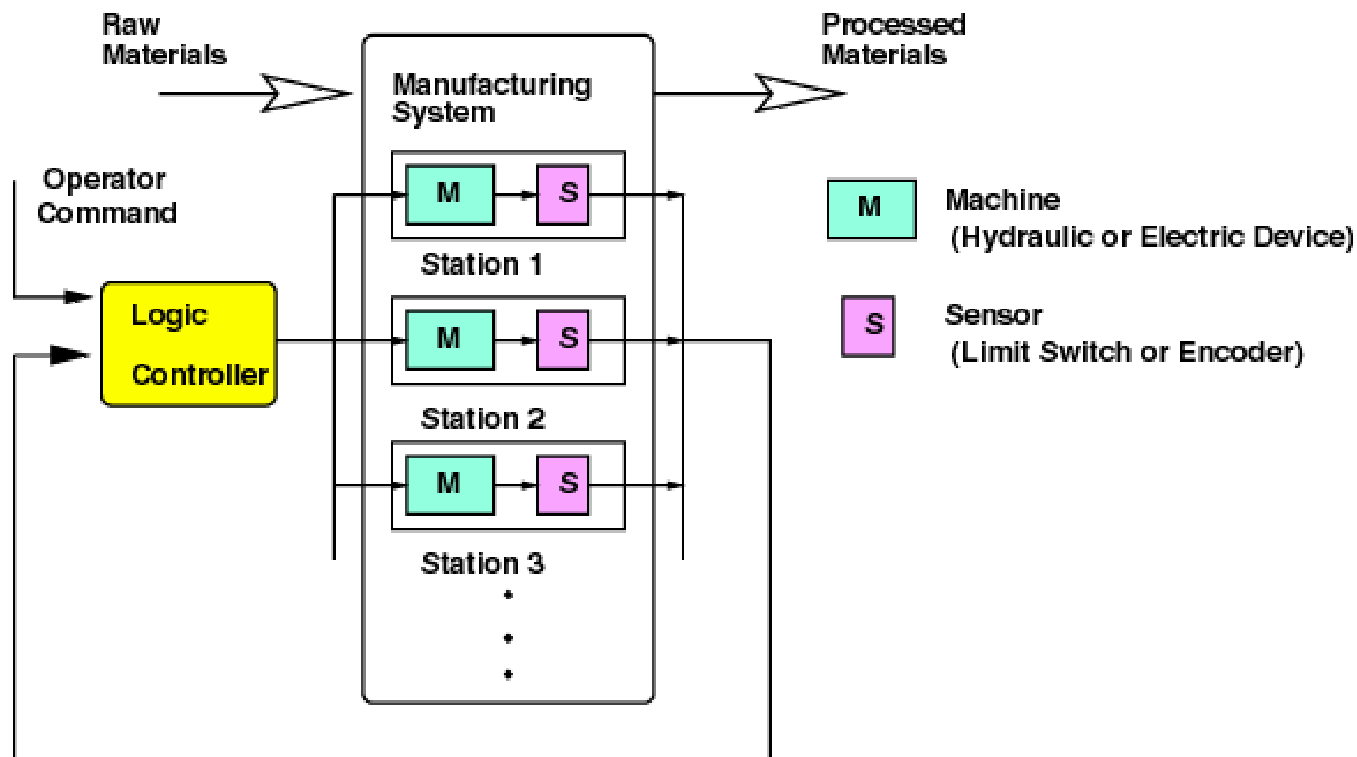

Formal representation of control

- **Petri net: Bipartite graph**
 - **Places (states) model operations: active or idle**
 - Token (dot) marks active state
 - **Transitions model events: from sensors or operator commands**

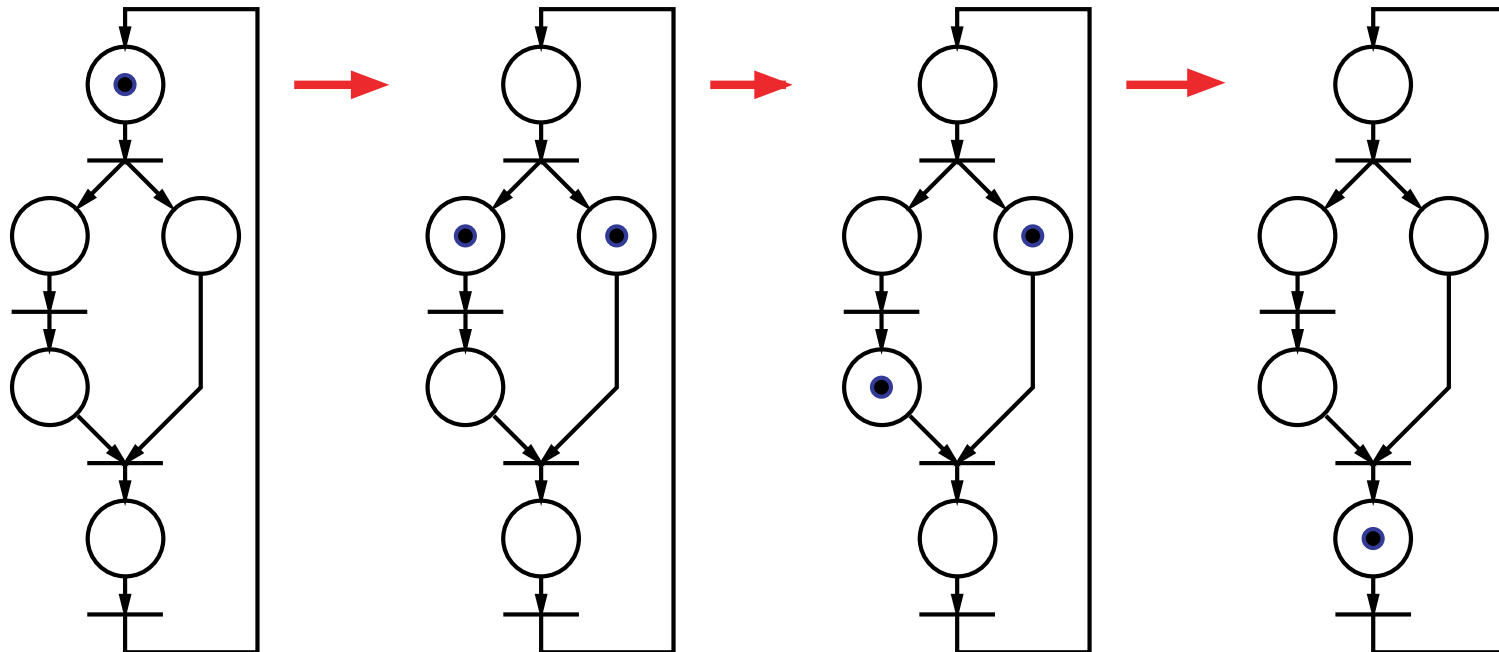

Advantages of Petri net models

- **Large base of existing theory**
- **Verification of key properties of control**
- **Hierarchical structures for complexity management**
- **Implementation in PLC**
 - **SFC = IEC standard programming language**
 - **One-one translation from Petri net to SFC**

Petri net model capabilities

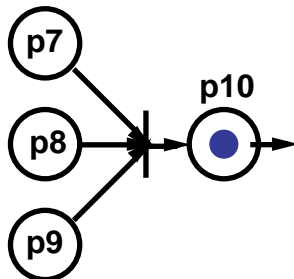
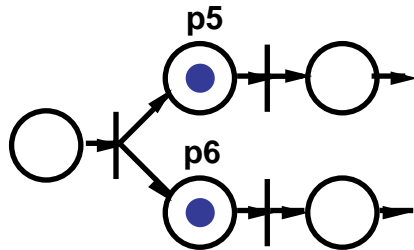
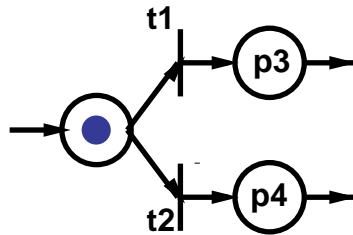
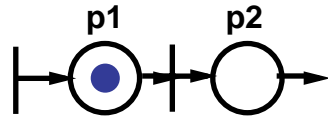

- **Causal dependency**
 - p1 occurs before p2
- **Conflict**
 - Only one of p3, p4 can occur
 - Transition conditions t1, t2 must be mutually exclusive
- **Concurrency**
 - p5, p6 active simultaneously
- **Synchronization**
 - p10 cannot begin until p7, p8, p9 have finished

Petri net properties for logic control

- **Live:** every transition can eventually occur
 - No deadlocks
 - All operations and events can happen
- **Safe:** No more than one token per place
 - Ongoing operations are not requested
 - Boolean state representation (active, inactive)
- **Reversible:** Initial state always reachable
 - Guarantees cyclic behavior of system

Supervisory control problem

- Petri net control models desired closed-loop behavior of system
- Control actions generated based on desired state

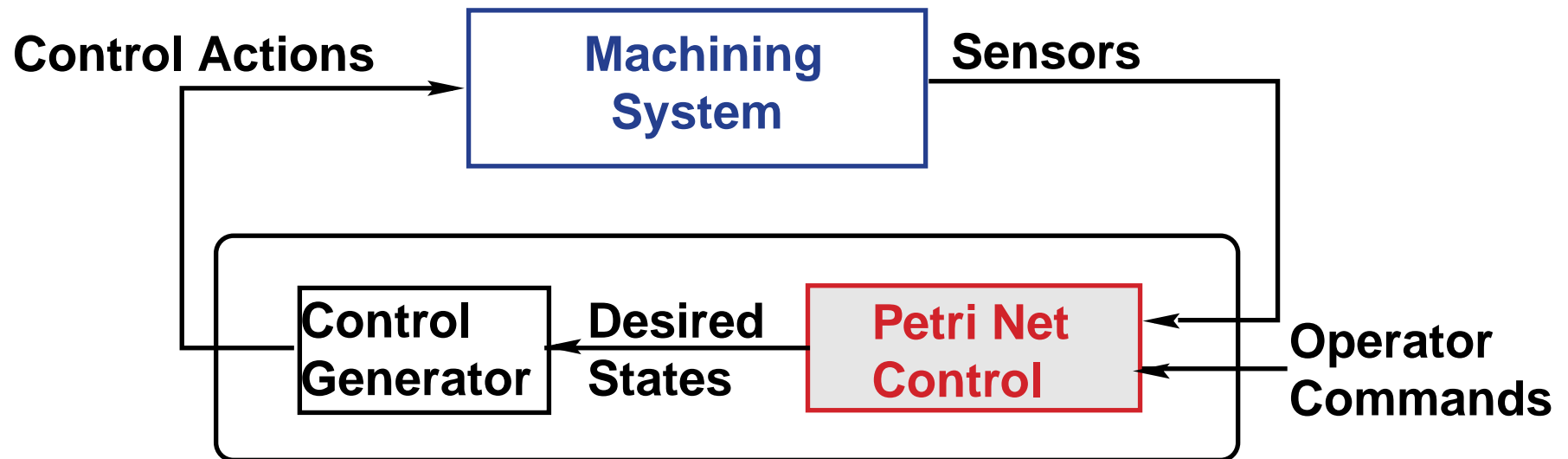

Outline

- **Motivation: Logic control problem for high-volume machining systems**
- **Background**
- **Automatic cycle logic control**
- **Multi-mode logic control**
- **Implementation and future work**

Auto mode

- **Normal operation cycle**

- Unclamp parts
- Raise transfer
- Advance transfer
- Lower transfer
- Clamp parts
- Cycle machining stations
- Return transfer

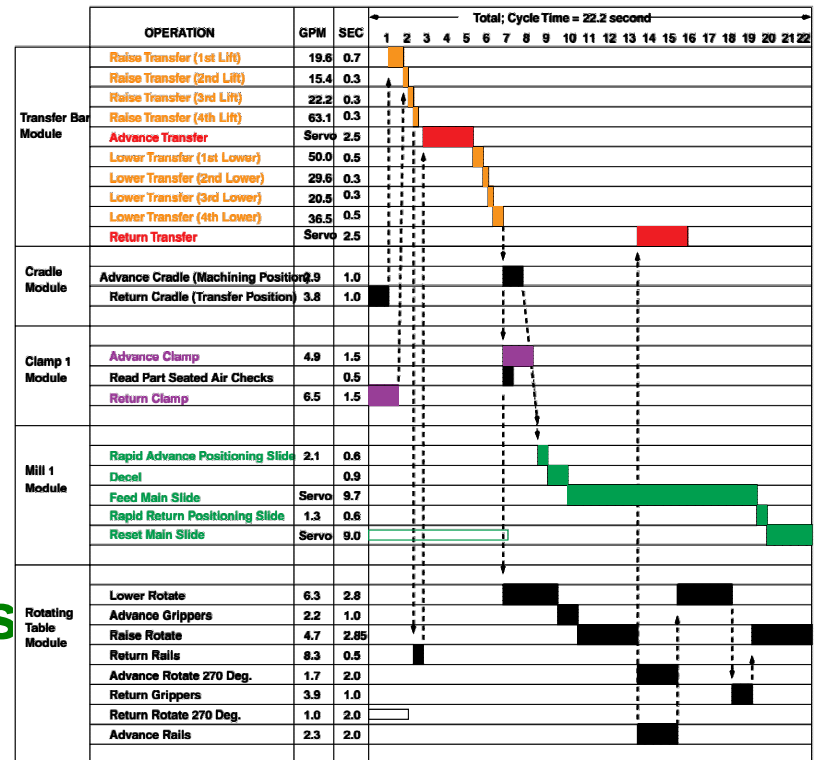

- **Overlapping to minimize cycle time**
- **Fault diagnosis and fault stop**

Timing bar chart -> Petri net

- Each mechanical module gives one directed circuit
- Add wait states before **synchronized transitions** to model operation termination

Module	Activity	Start (s)	End (s)
Mill 1 Module	Rapid Advance Positioning Slide	2.1	0.6
	Decel.		0.9
	Feed Main Slide	Servo	9.7
	Rapid Return Positioning Slide	1.3	0.6
	Reset Main Slide	Servo	9.0

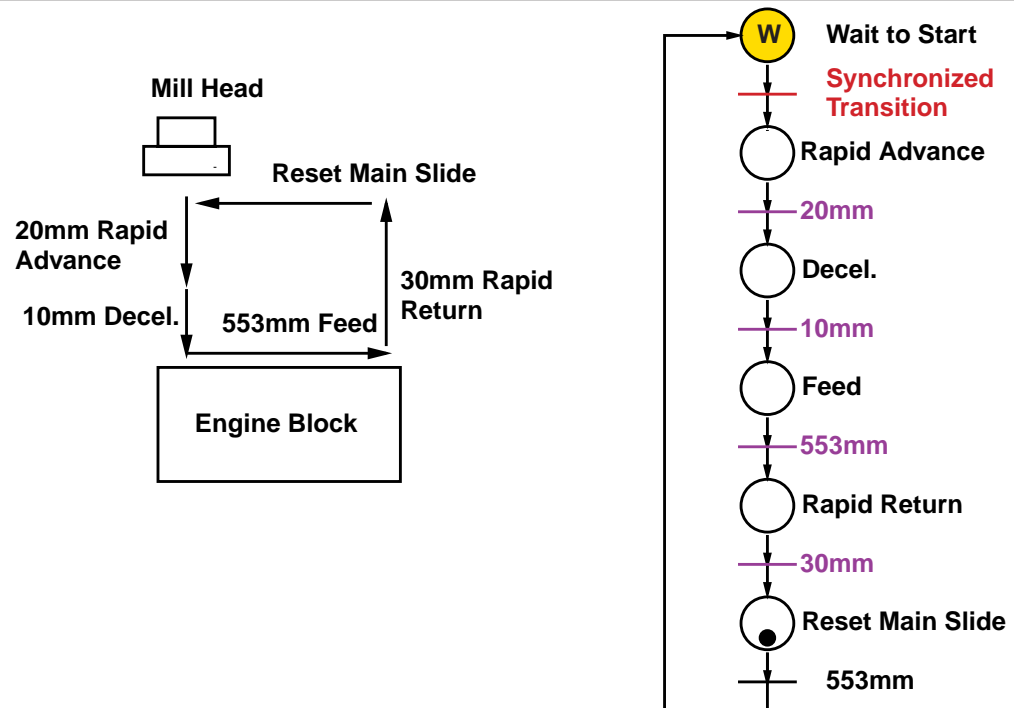

Hierarchical representation

- Reduce complexity of Petri net by combining sets of places/transitions
- Preserves liveness, safeness, reversibility

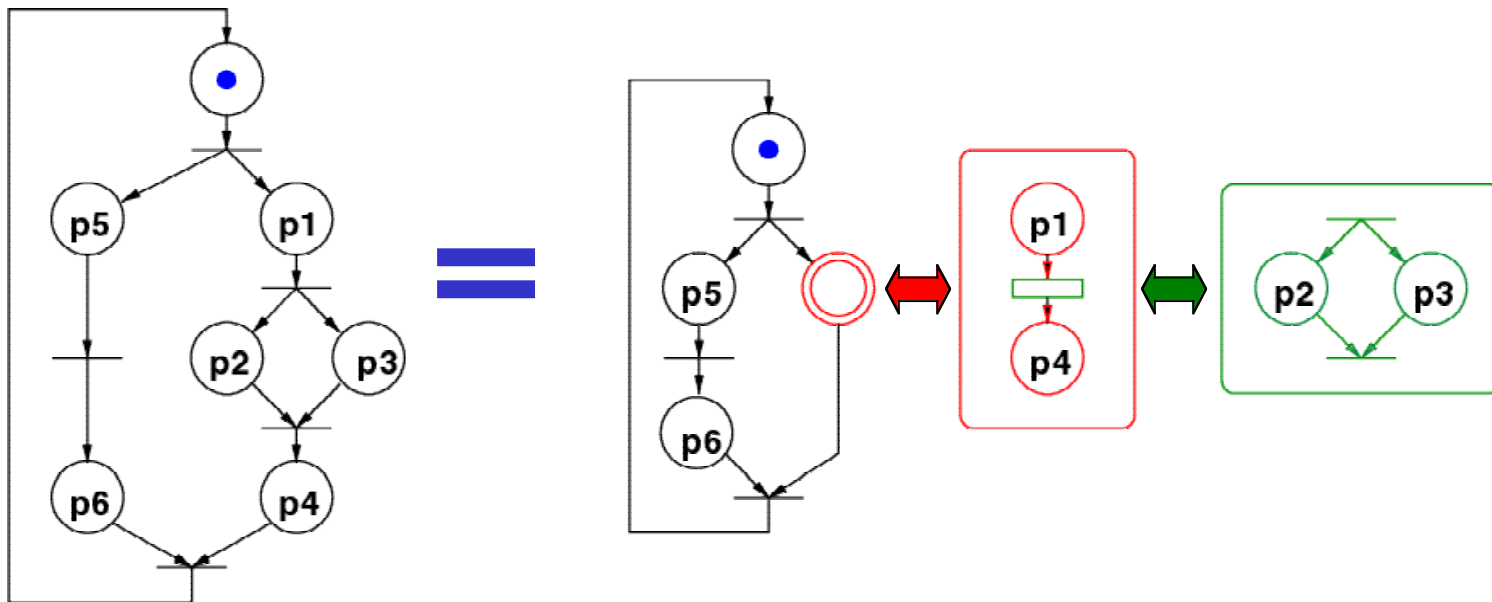

Combining control modules

- Merge **synchronized transitions**
- Synchronized transitions retain physical meaning
- Add wait states (W) before synchronized transitions to model operation completion

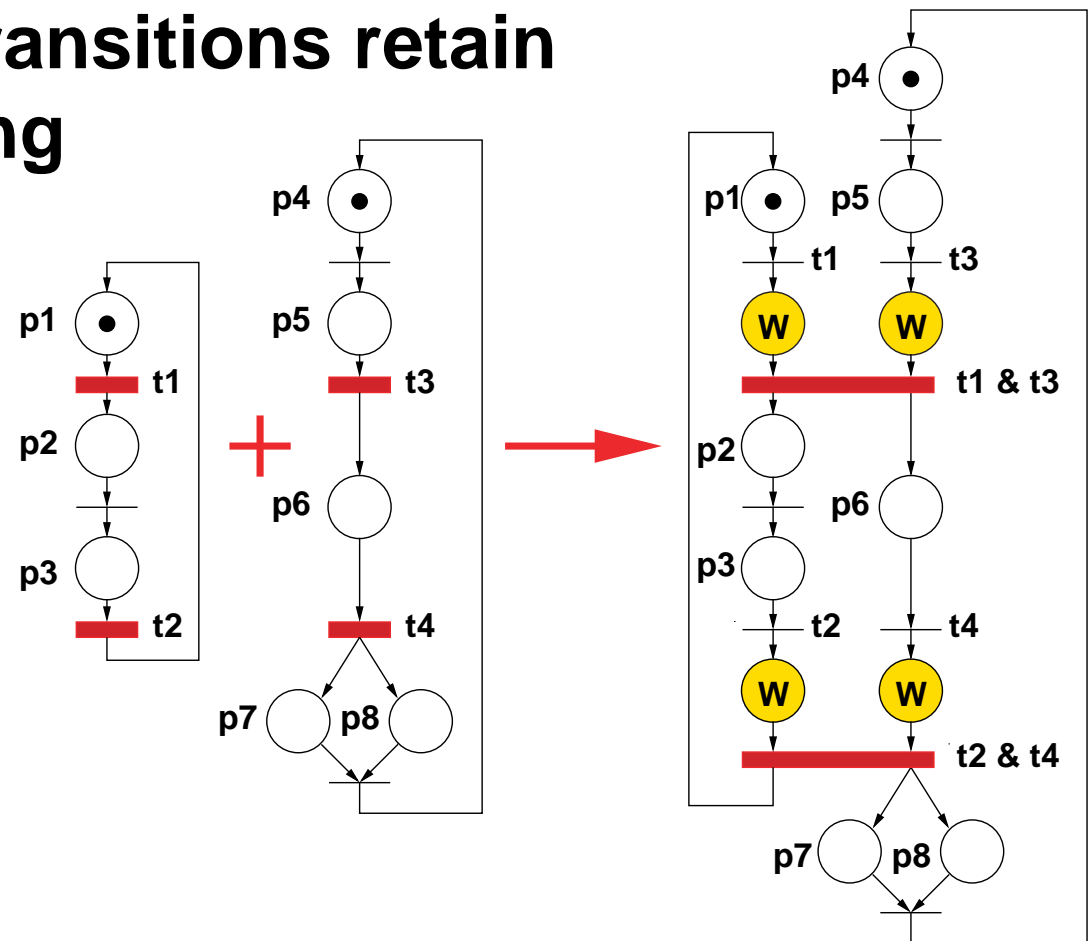

Logic control for automatic cycle

- Directly generated from timing bar chart
- Guaranteed to be live, safe, reversible

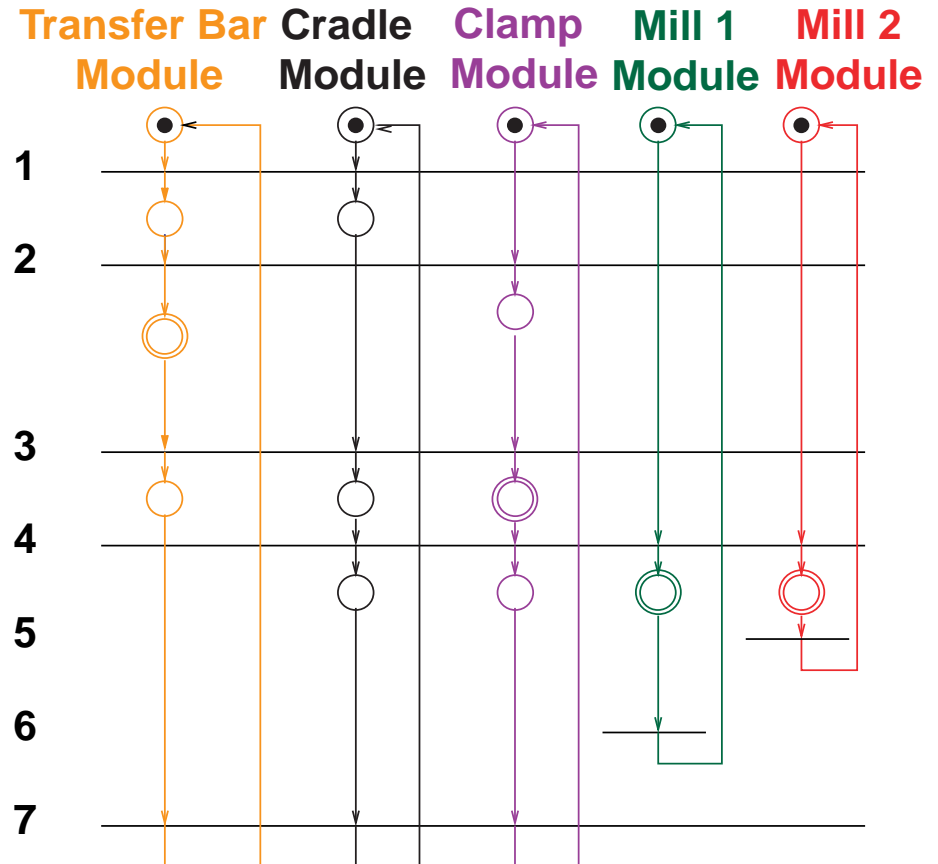
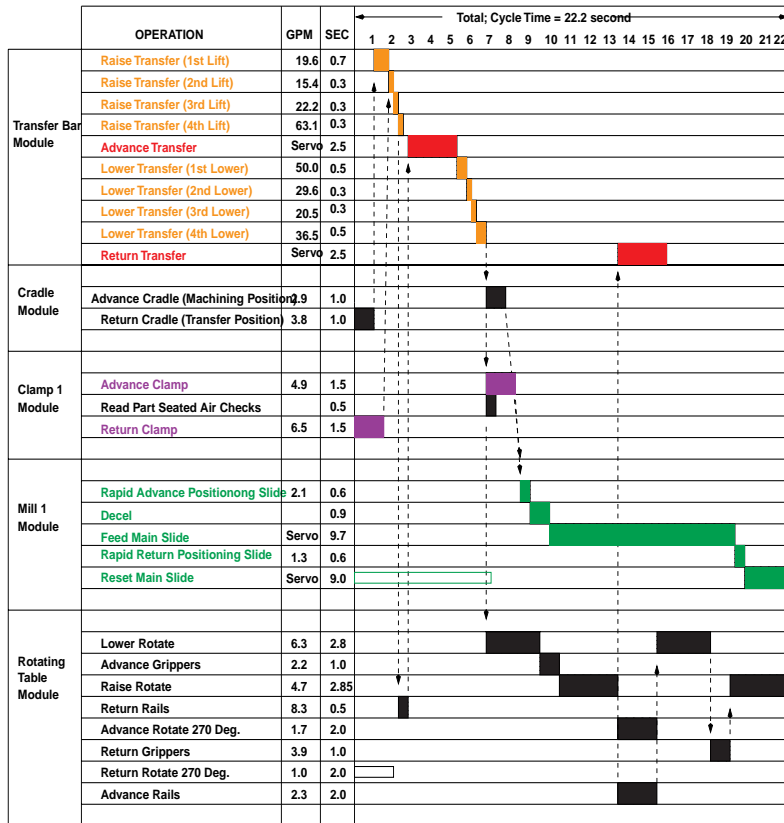

Reconfiguration of logic control

- Add a new mill to transfer line
- New logic for mill & clamp
- Modify transfer bar logic to synchronize with clamp
- Shaded logic unchanged

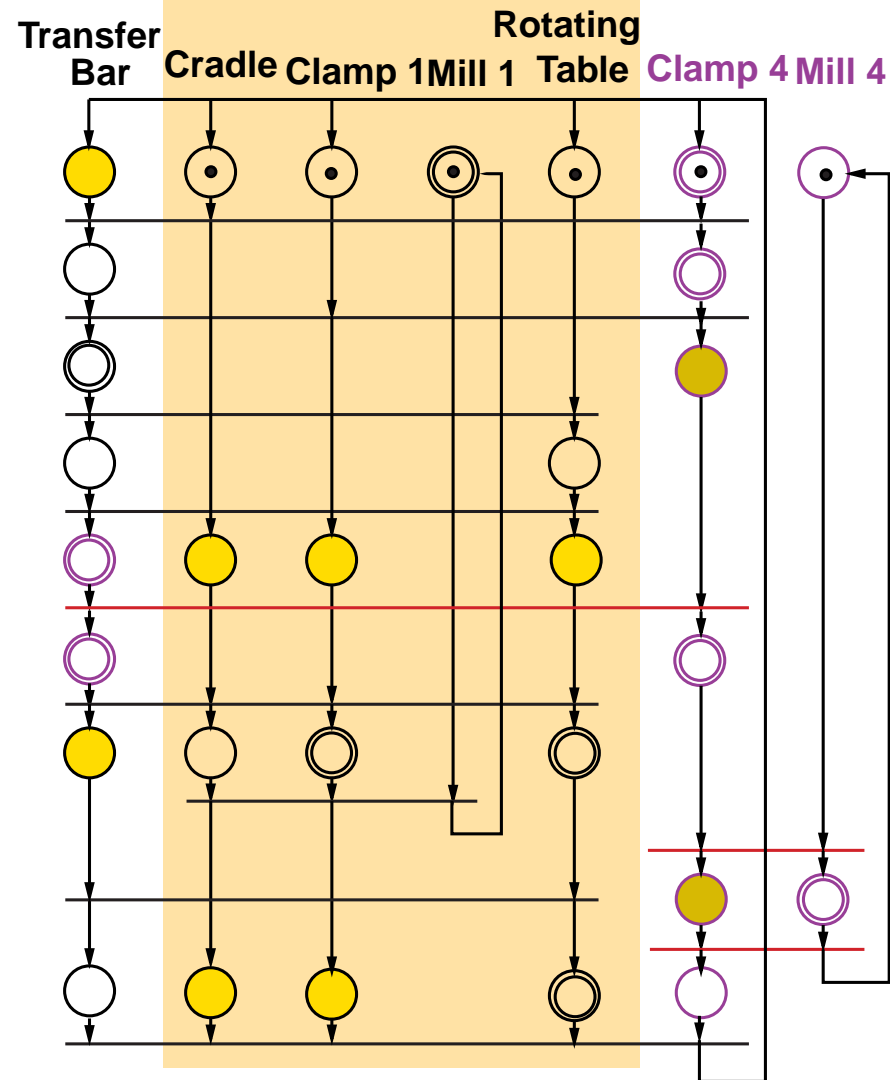

Modular structure of control

- Transfer bar synchronizes all modules
- Limited communication
- Ease of modification

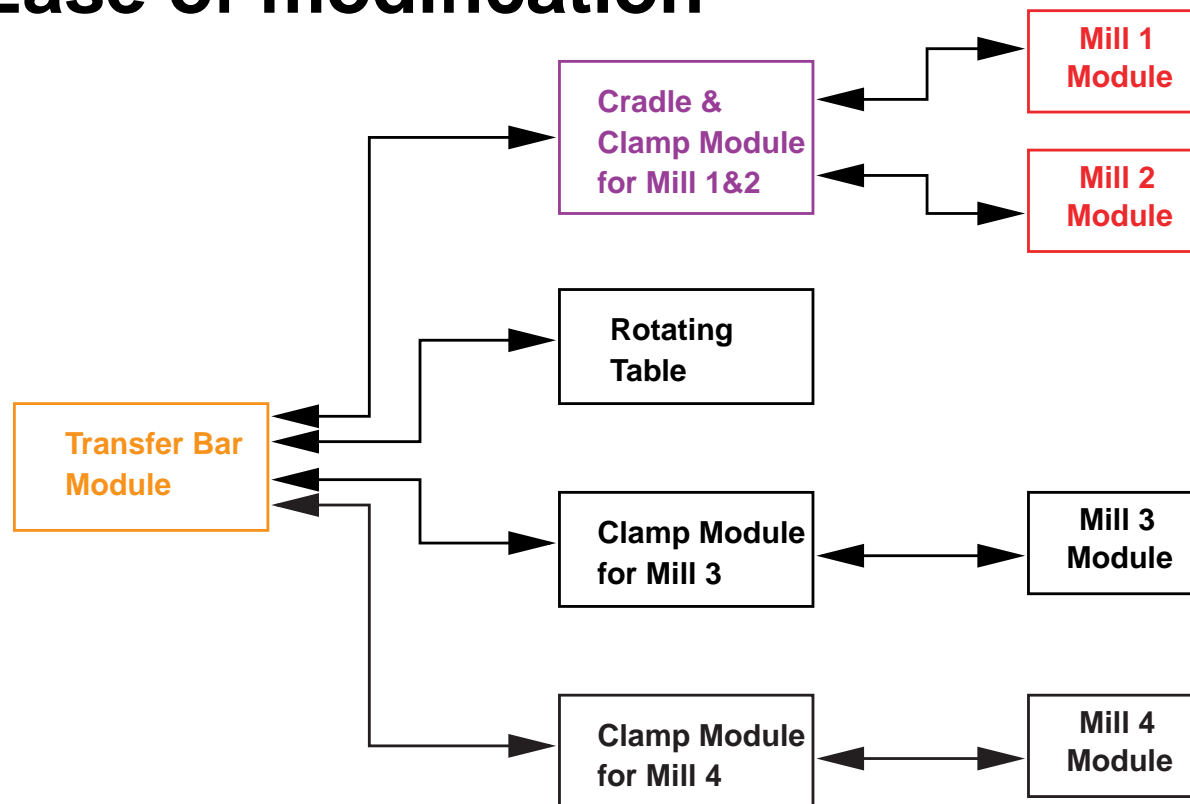

Outline

- **Motivation: Logic control problem for high-volume machining systems**
- **Background**
- **Automatic cycle logic control**
- **Multi-mode logic control**
 - **What happens when things go wrong?**
- **Implementation and future work**

Operator interaction with control

- **Manual mode**
 - Single station fine operation control
- **Hand mode**
 - Normal operation cycle without overlapping
 - Reverse sequences possible

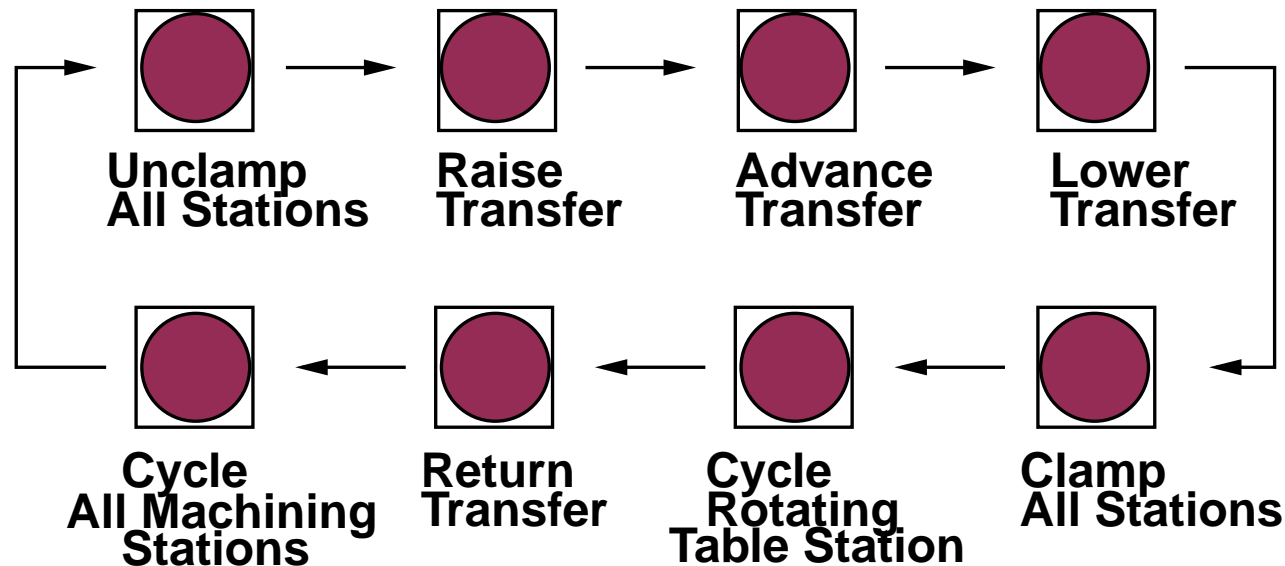

Three states for each operation

- **Operating:**
 - Activate actuator
- **Completed stop:**
 - Deactivate actuator
 - Set internal variable to 1
- **Incomplete stop:**
 - Deactivate actuator
 - Announce fault

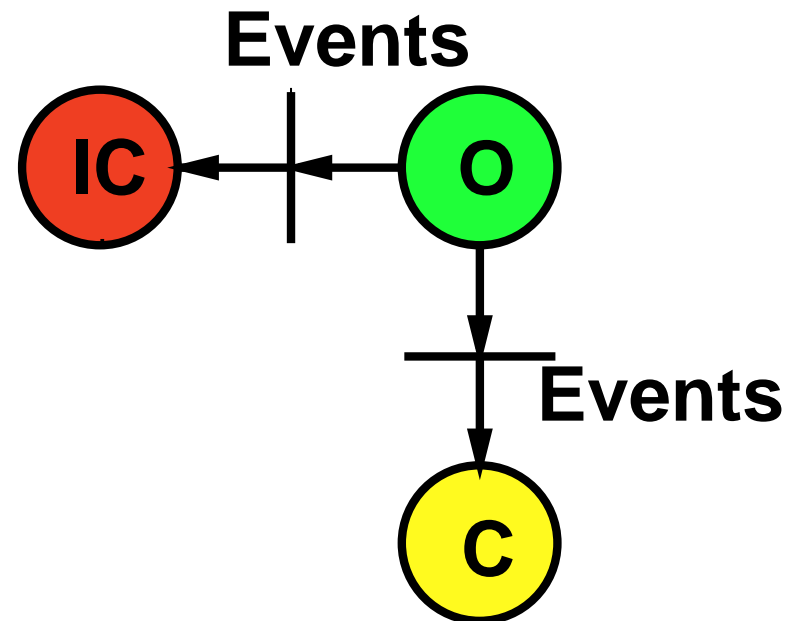

- **Sensors trigger transitions between states**
- **Internal variable used for coordination with other stations**

Internal variables to synchronize

- Synchronization conditions depend on control mode
- Decouple each control module

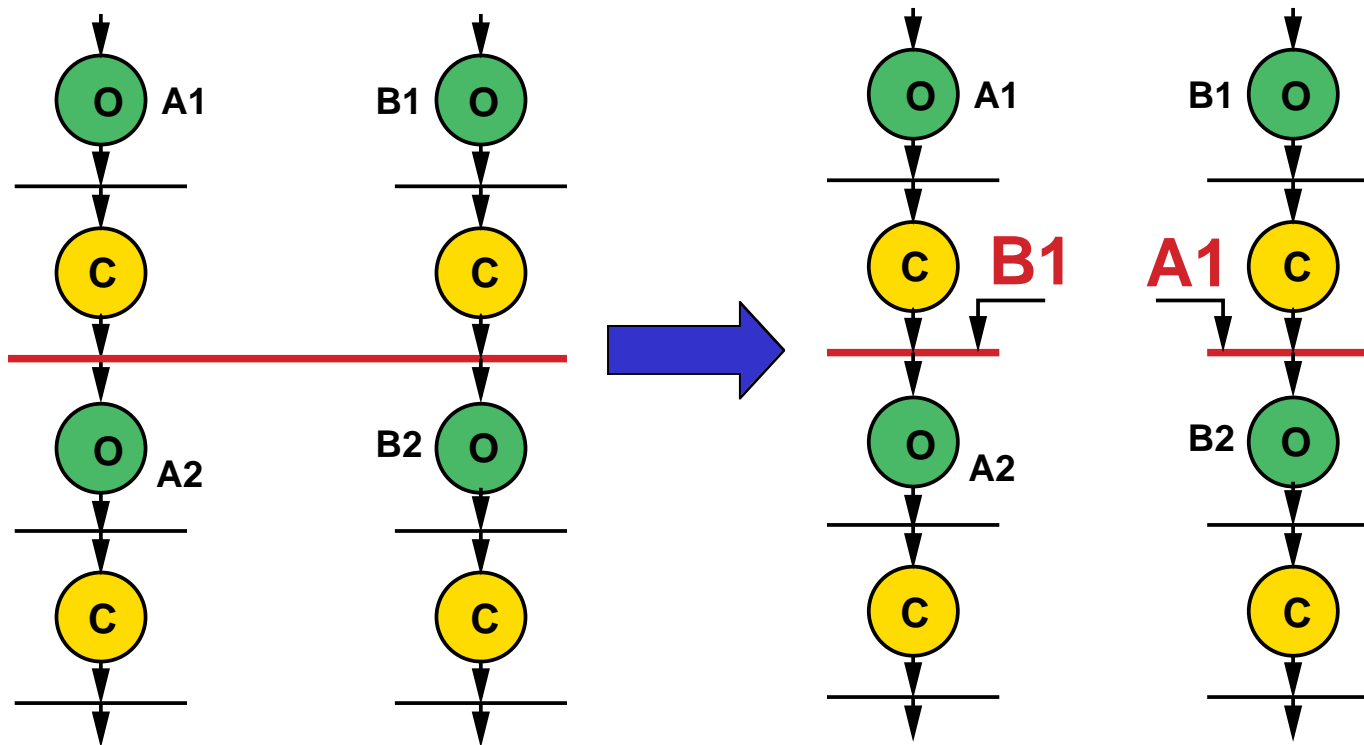

Reversible operation module

- Normal and fault recovery operations
- Fault recovery:
 - Restart from fault position
 - Return to initial position of operation, then restart
- Faults may occur in fault recovery operation
- Transitions triggered by operator commands advance (a) and return (r) in manual mode

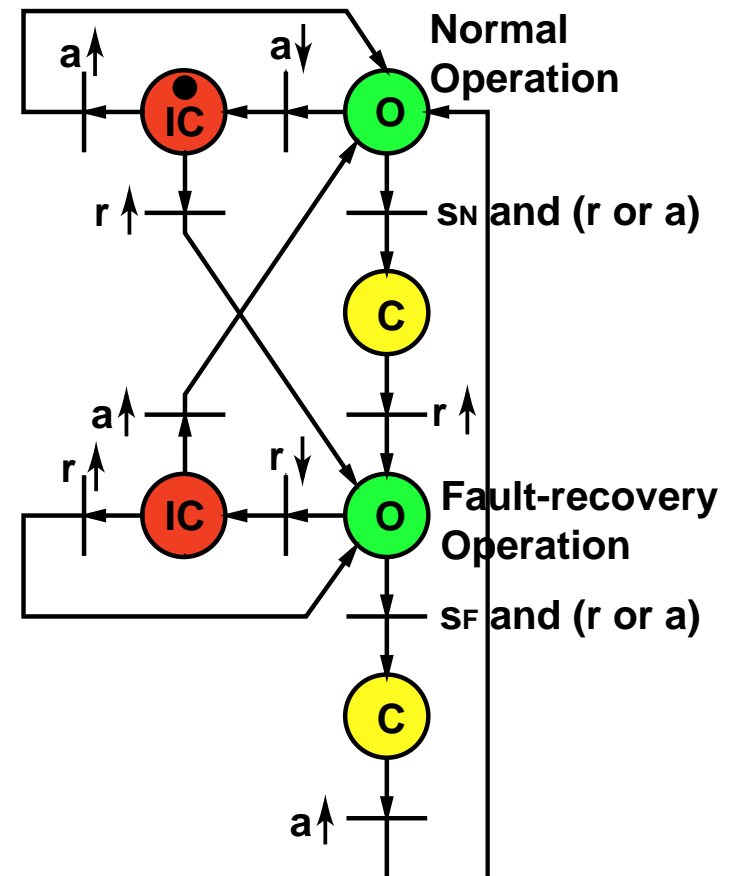

Irreversible operation module

- Metal-removal operations (i.e. milling)
- Only contains normal operation block
- Fault recovery:
 - Restart from fault position
 - Return to home position of machining station and restart
- Transitions triggered by operator commands advance (a) and return (r) in manual mode

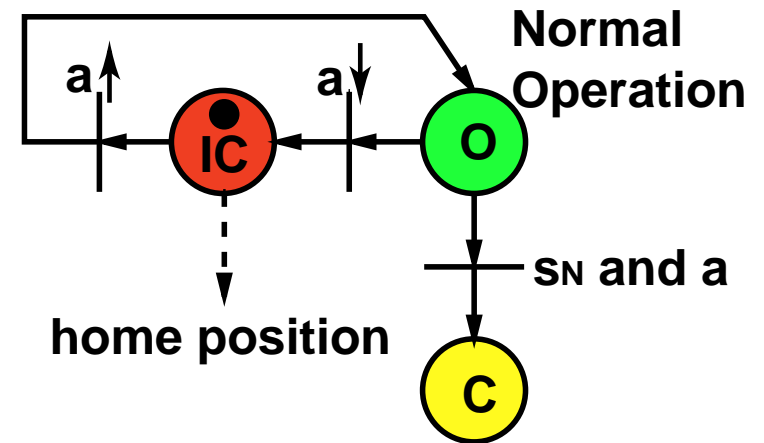

Combining control modes

- Same set of states for all modes
- Transition conditions depend on active control mode
- **Superposition** preserves liveness, safeness, reversibility properties

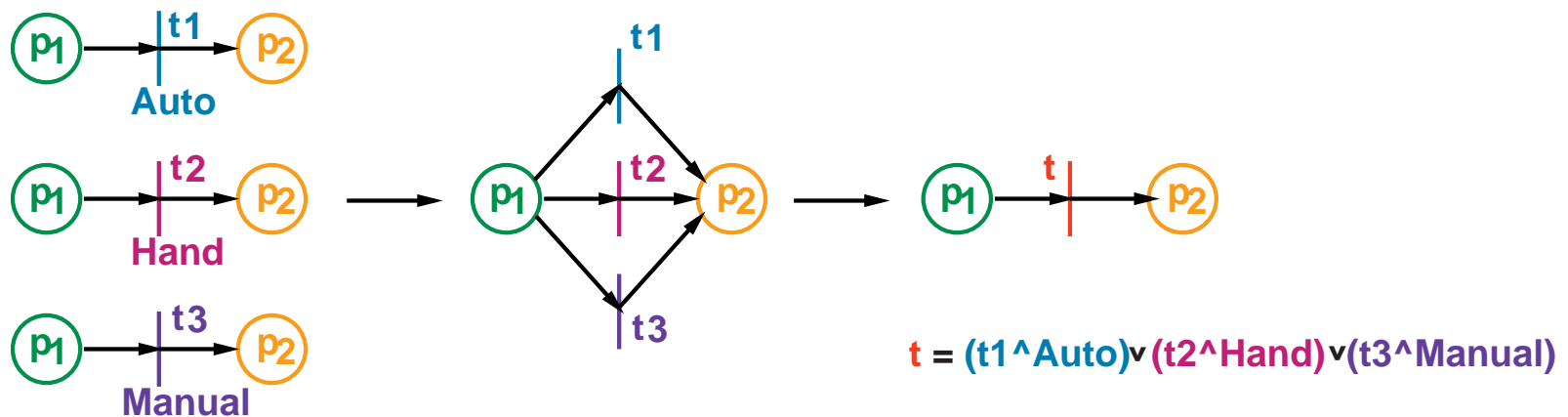

Algorithm to build logic controller

1. Assign module for each operation
2. Normal operation cycle ordered as in timing bar chart
 - Mill example: Advance, Feed, Return

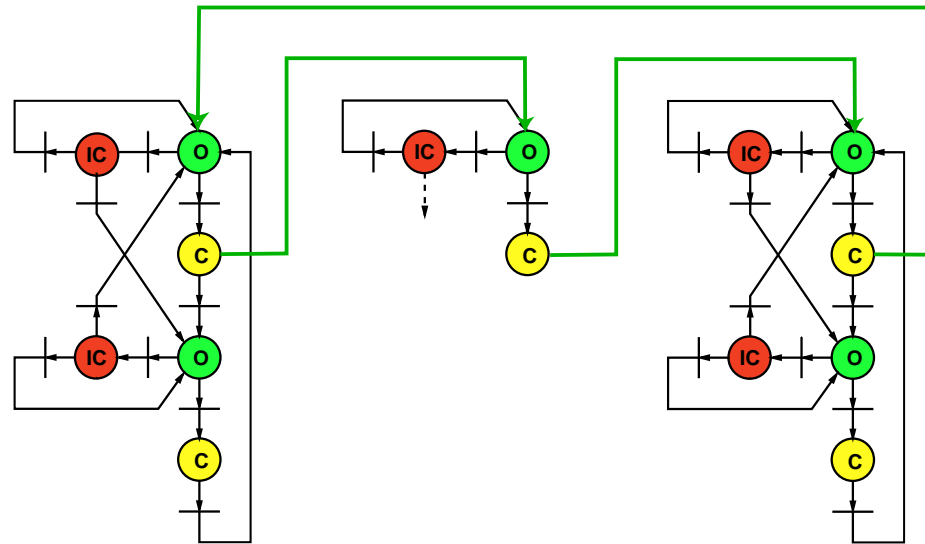

Algorithm to build logic control

3. Reverse sequences for repeatable steps in hand mode
4. Fault recovery sequences for irreversible operations

Theorem: Station control module constructed according to algorithm is **live, safe, and reversible** Petri net.

Mode decision control logic

- Mode chosen by operator from input panel
- Mode decision control logic is **live, safe, reversible**

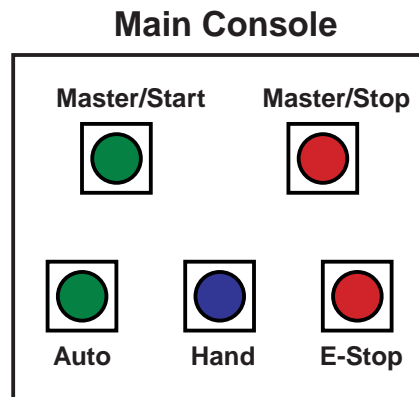

Each Station

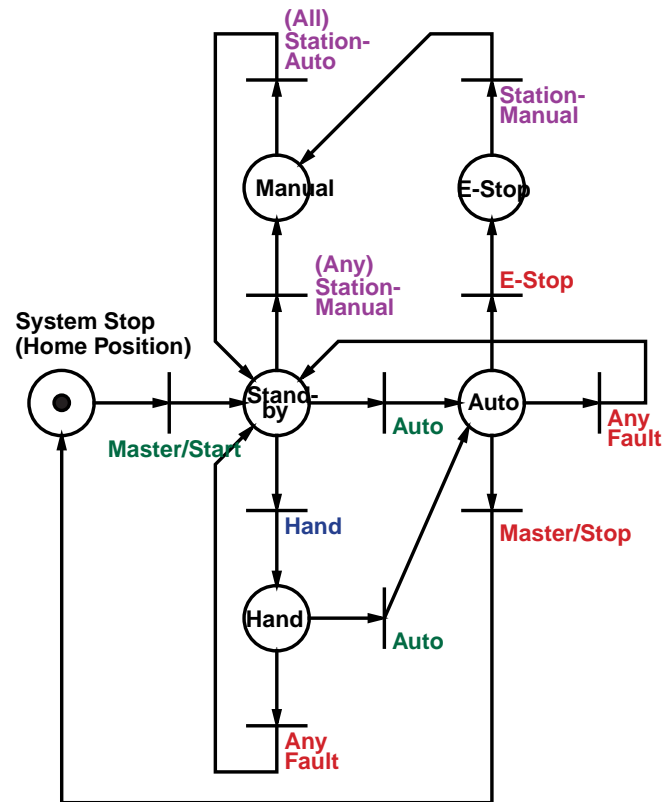
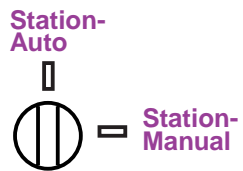

Modular logic controller

- Operation causality condition to ensure well-ordered set of operations
- Station logic controllers with mode decision control logic

Theorem: Resulting controller is guaranteed to be **live, safe, reversible**









Outline

- **Motivation: Logic control problem for high-volume machining systems**
- **Background**
- **Automatic cycle logic control**
- **Multi-mode logic control**
- **Implementation and future work**
 - **To the factory floor**

Implementation in PLC

Sequential function charts (SFC)

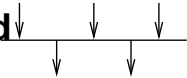
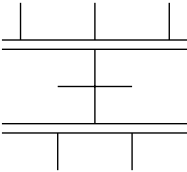
- IEC 1131-3 standard language
- Based on Petri nets
- One-one translation

Marked Graph	SFC/Grafcet
Simple Place 	Simple Step 
Initial Place 	Initial Step 
Simple Transition 	Simple Transition 
Synchronized Transition 	Synchronized Transition 
Macro Place 	Macro Step 

Industrial implementation

- **US Patent applied for, 1998**
- **Current cooperation with Lamb Technicon on Cummins Engine project**
- **Evaluating implementation needs**
 - **Machine services**
 - **Safety and gate interlocks**
 - **Reusability**
 - **PLC platform dependence**
 - **User interface**
- **Commercialization potential**

Future of reconfigurable control

- **Unified framework for continuous and discrete control for machining systems**
 - Modular structures for reconfigurability
 - Mathematical basis for verification
 - Integrated diagnostics
 - Automatic fault detection and recovery
- **Software tools for control design/analysis**
 - Interface with mechanical design software
 - Automatic control code generation