

## DESIGN FOR EXISTING LINES: PART AND PROCESS PLAN OPTIMIZATION TO BEST UTILIZE EXISTING PRODUCTION LINES

Arlene G. Smithson<sup>§</sup>

NVFE Laboratory  
Environmental Protection Agency  
2565 Plymouth Road  
Ann Arbor, MI 48105  
[smithson.arlene@epa.gov](mailto:smithson.arlene@epa.gov)

Karim Hamza

Dept. of Mechanical Engineering  
University of Michigan  
Ann Arbor, MI 48109-2125  
[khamza@umich.edu](mailto:khamza@umich.edu)

Kazuhiro Saitou\*

Dept. of Mechanical Engineering  
University of Michigan  
Ann Arbor, MI 48109-2125  
[kazu@umich.edu](mailto:kazu@umich.edu)

### ABSTRACT

This paper presents a method for modifying the design of the new part for the maximum utilization of existing production lines dedicated to other products. The method takes as inputs a nominal part design and the process information of the (potentially multiple) existing line(s), and produces a modified part design and a process sequence of the new part that maximizes the utilization of available manufacturing processes in the existing lines or equivalently minimizes the addition of new processes dedicated to the new product. The problem is formulated as mixed discrete-continuous multi-objective optimization and a multi-objective genetic algorithm is used to generate Pareto optimal designs. A case study on the production of a new machine bracket considering two available production lines is presented.

### 1. INTRODUCTION

Ever-increasing trends for more product varieties and shorter lead times are pressuring manufacturers more than ever to investigate ways to minimize production costs and maximize earnings. Due to the large capital cost for setting up a new production line, many manufacturers opt for the reuse of the existing production lines as an effective way of reducing the cost of introducing a new product into the market. While a lower cost can be achieved by utilizing the existing production resources, however, undesired compromise in the product function due to the utilization of existing resources would result in quality loss and/or a longer design cycle due to unnecessary redesign at a later stage. Therefore, a systematic design method is desired that facilitates the optimal "casting" of a new product design into the existing production resources without affecting the intended product function.

As an illustration, consider the simple machined products shown in Fig. 1, where Fig. 1(a) shows the part currently produced in an existing production line (Fig. 2), and Fig. 1(b) shows the new part under consideration. Assuming no flexibilities in fixturing size and tool motion, the fixtures of the existing line cannot hold a 2x2 stock, which is a minimum size stock for the new product. If a 2x2 stock is to be utilized, the new part must be manufactured without utilization of the existing processes, for instance, the sequence shown in Fig. 3.

On the other hand, careful examinations of the critical dimensions of the existing and new products (indicated by circles in Fig. 1) reveals that, with some material waste, a 2x3 stock can be utilized to enable the use of existing processes without compromising an intended function of the new product. Fig. 4 shows such an example process sequence of the new part, with two of the existing processes and one new process. In Fig. 4(e), the part width is kept as 3 since it was not indicated as a critical dimension in Fig. 1(b). This means, for better utilization of the existing manufacturing processes, the initial part design in Fig 1 (b) can be modified to a width of 3 without compromising the intended part function.

If the reduction of part width is desired, additional new process can be added at the end to cut off the extra width. The additional part width in Fig. 4 was added merely to facilitate the fixturing by the existing fixtures with no other functions. Such geometric features, which we refer to as *fixturing features*, can greatly enhance the utilization of the existing processes.

This research aims at developing a method for modifying the design of a product, considering the in-progress part geometry and manufacturing process sequence, for the maximum utilization of existing production lines dedicated to other products. The method takes as inputs a nominal part

<sup>§</sup> D. Eng. in Mfg. from the University of Michigan, Ann Arbor

\* Corresponding author

design and the process information of the (potentially multiple) existing line(s), and produces a modified part design and a process sequence that maximizes the utilization of available manufacturing processes in the existing lines or equivalently minimizes the addition of new processes dedicated to the new product. The problem is formulated as mixed discrete-continuous multi-objective optimization and a multi-objective genetic algorithm is used to generate Pareto optimal designs.

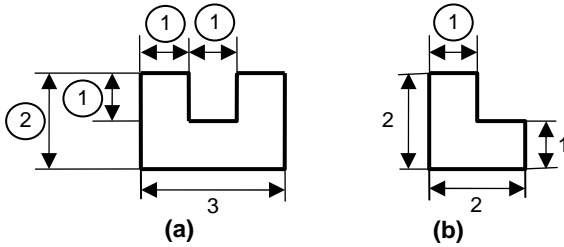

**Fig. 1. (a) part manufactured by an existing line and (b) new part. The critical dimensions, for which both of the end faces are milled, are indicated by circles.**

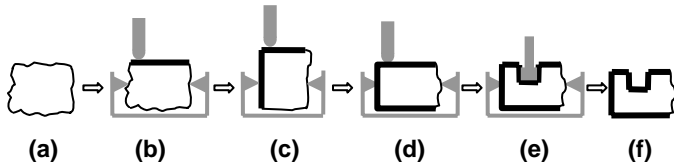

**Fig. 2. Process sequence of the existing line. (a) stock, (b) bottom face milling ( $p_1$ ), (c) left face milling ( $p_2$ ), (d) top face milling ( $p_3$ ), (e) slot milling ( $p_4$ ), and (f) finished part**

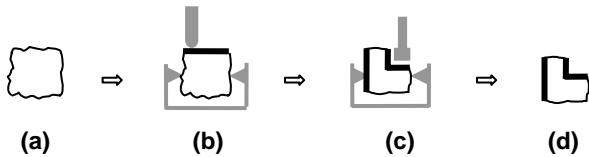

**Fig. 3. A possible process sequence of the new product without utilizing processes in the existing line. (a) stock, (b) left face milling, (c) slot milling, and (d) finished part**

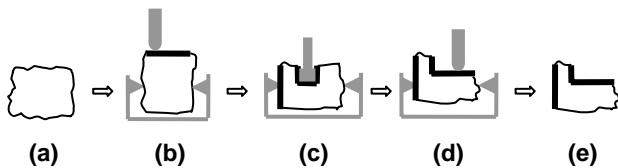

**Fig. 4. Alternative process sequence for new part utilizing two processes in the existing line. (a) stock, (b) left face milling ( $p_2$ ), (c) slot milling ( $p_4$ ), (d) face milling (new process), and (e) finished part. Part width is not reduced to 2 since it is not indicated as critical**

The method, which we shall refer to as Design for Existing Lines (DFEL), is highly effective during the introductory phase of a new product into a product portfolio, when increasing volume of new products must be accommodated in an economical fashion while maintaining the high production

volume of existing products [1]. The successive application of DFEL during the transition of an old product to a new product would facilitate the incremental changes in the production facilities from the one dedicated to the old product, eventually to the one dedicated to the new product. Also, DFEL provides an alternative to the use of flexible manufacturing cells [2] for small batch, custom-made products, for which building a dedicated line cannot be justified.

The following sections provide a brief review of the relevant literature, a problem formulation, and a case study on the production of a new machine bracket considering two available production lines. The paper concludes with a discussion.

## 2. LITERATURE REVIEW

DFEL belongs to a general area of Design-for-X (DFX) methods, where X can be manufacturing, assembly, environments ...etc, depending on the purpose for which a product design is improved. Design for Manufacturing (DFM) [3-5] and Design for Assembly (DFA) [5, 6] provide generic design guidelines to modify part designs for lower manufacturing and assembly cost. While the guidelines are specific to the type of production processes, *eg.*, machining and manual assembly, they are still generic to assure the applicability to various situations. Also, the guidelines are process-oriented rather than systems-oriented. While effective as genetic methods, both of these characteristics makes DFM and DFA fall short for enhancing the reuse of a specific production facility. On the other hand, Design for Existing Environment (DFEE) [7] and Design for Production (DFP) [8] provide means for evaluating a product design based on the system-level information specific to the target production facility such as process plans, cycle time, and production capacity. While key system-level issues are considered, however, they do not explicitly deal with part geometry that is essential to determine the reusability of a production process [9-13]. For this reason, these methods cannot effectively address the partial utilization of existing facilities based on in-process part geometries nor synthesize a modified part geometry as an end result.

Since the reusability of an existing process depends on the similarity of the current part and new part, a system for measuring similarity of part geometry is relevant. Group Technology (GT) [14-18] serves this very purpose. While GT provides a system for classifying parts based on the similarity of their manufacturing processes, it is merely a coding system without an explicit consideration of process sequence and therefore in-process geometries. Computer-aided process planning (CAPP) [19-24], on the other hand, explicitly deals with both process sequence and in-process geometries to synthesize the process plan best suited for a given part geometry, through either modifying an existing process plan for a similar part or searching among the feasible plans that satisfy the process precedence imposed by the part geometry. While GT and CAPP attempt to link part geometry and production system design, they regard part geometry as a given input, with no consideration of redesign for better utilization of existing facilities as addressed in the proposed method

Dissimilar to other DFX methods stated above, DFEL assumes the existence of specific production lines, and synthesizes (rather than evaluates) the modified product design for improved utilization of the existing lines, by simultaneously considering in-process part geometries and process sequencing as CAPP. Focusing on machined parts, the demonstration in this paper in essence extends Design for Fixturability [25] method into multi-process, dedicated production lines. Since the reusability of an existing process is determined based on the fixturing envelope and the in-process part geometries, both partial and total utilization of the existing lines can be seamlessly addressed.

### 3. APPROACH

Given the design of a new part and the process information of the existing lines (potentially multiple), DFEL outputs a modified part design and a process sequence that maximizes the utilization of available manufacturing processes in the existing lines. The outputs are obtained by solving the multi-objective optimization problem described in section 3.4. While the concept of DEFL is applicable to many domains, this paper focuses on the geometric aspect of machined parts and assumes 1) single parts, not assemblies, 2) linear production line with no branching, consisting of machining processes only, 3) no part deformation during fixturing and machining, and 4) no machine reconfiguration in the existing production lines.

#### 3.1 Definition of inputs

For simplicity of notation, a nominal part geometry, either in-process or finished, is represented in this section as a subset 3D space  $\mathbf{R}^3$  and a production line is represented as a mapping from  $\mathbf{R}^3$  to  $\mathbf{R}^3$ . A problem-specific parameterization of the part geometry should be adopted in the actual implementation of the DFEL method, such as the one in the case study.

Geometry  $s \subset \mathbf{R}^3$  of a new part consists of critical and non-critical design features, which are specified as a set of value ranges (or single values) of part dimensions as illustrated in Section 1. While the out-of-range non-critical features do not affect the intended function of the part, the critical features within the acceptable range must be present in the part geometry for the part to be functional. The part geometry is also indirectly represented by  $MF = \{mf_1, mf_2, \dots, mf_l\}$ , a partially-ordered set of  $l$  machining features that are minimally required to machine all critical design features, starting from a material stock.

A production line  $\mathbf{p} = \langle p_1, p_2, \dots, p_m \rangle$  is a linear sequence of  $m$  machining operations  $p_j = (r_j, o_j, E^{min}_j, E^{max}_j); j = 1, 2, \dots, m$ , where function  $r_j: 2^{\mathbf{R}^3} \mapsto 2^{\mathbf{R}^3}$  is the relocation of incoming part<sup>1</sup>, function  $o_j: 2^{\mathbf{R}^3} \mapsto 2^{\mathbf{R}^3}$  is the actual machining operation, and set  $E^{min} \subset \mathbf{R}^3$  is the minimum and  $E^{max} \subset \mathbf{R}^3$  is the maximum fixturing envelope of the operation, respectively. At process  $p_j$ , an incoming part  $s_{j-1}$  is first relocated and fixtured, and then machined to produce an outgoing part  $s_j = o_j(r_j(s_{j-1}))$ , as illustrated in Fig. 5. Starting with a material

stock  $s_0$ , a production line sequentially transforms the part geometry  $s_1, s_2, \dots$  to finally produce a finished part  $s_m$ . Multiple production lines are differentiated by an additional (preceding) subscript, where  $\mathbf{p}_1, \mathbf{p}_2, \dots, \mathbf{p}_n$  denote the  $n$  existing production lines. The subscript 0 is reserved for the production line of the new product.

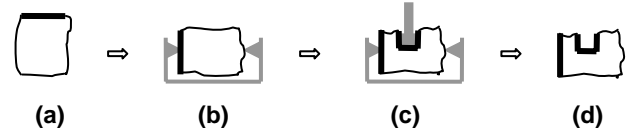

Fig. 5. Representation of the  $j$ -th operation  $p_j$  in a production line. (a) incoming part  $s_{j-1}$ , (b) relocation  $r_j$  (c) machining operation  $o_j$ , and (d) outgoing part  $s_j = o_j(r_j(s_{j-1}))$

#### 3.2 Definition of design variables

The design variables are:

- Stock geometry  $s_{00} \subset \mathbf{R}^3$  of the new part.
- Number of machining operations  $m_0 \in \mathbf{Z}_+$  in the production line of the new part.
- Sequence of machining features  $e = \langle e_1, e_2, \dots, e_l \rangle$  to produce the new product, where  $e_j \in \{1, 2, \dots, l\}$  is the ID of the machining feature  $mf \in MF$  machined at the  $i$ -th operation in the production line of the new part.
- Machining operations  $\mathbf{q} = \langle q_1, q_2, \dots, q_{m_0} \rangle$  for the machining features of the new part, where  $q_k$  is the machining operation for the  $k$ -th machining feature  $mf_k \in MF$ . Each operation  $q_k$  can either be the one chosen from the existing lines  $\mathbf{p}_1, \mathbf{p}_2, \dots, \mathbf{p}_n$ , or a newly created operation. It is assumed that newly created operations can accommodate the machining of any desired features since they are custom made.

For a set of values of  $m_0, e$  and  $\mathbf{q}$ , the production line  $\mathbf{p}_0$  of the new product is uniquely specified as  $\mathbf{p}_0 = \langle p_{01}, p_{02}, \dots, p_{0m_0} \rangle$ , where  $p_{0j} = q_{e_j}$  for  $j = 1, 2, \dots, m_0$ . While the problem can be formulated with a given minimum stock size obtained from the nominal part geometry, the inclusion of stock shape and size  $s_{00}$  in design variables is essential to exploit the potential benefit of the fixturing features as illustrated in Section 1.

#### 3.3 Definition of constraints

The constraints are:

- Each machining feature is machined exactly once:
$$e_j \neq e_k \text{ for any } j \neq k; j, k = 1, 2, \dots, l \quad (1)$$
- Sequence of machining feature conforms the precedence:
$$mf_{e_j} \prec mf_{e_k} \text{ for any } j < k; j, k = 1, 2, \dots, l \quad (2)$$
- Each machining feature is machined by the operation with the compatible type:
$$\text{machinable}(mf_k, \text{type}(q_k)) = \text{true} \quad (3)$$

<sup>1</sup>  $2^{\mathbf{R}^3}$  is a power set (set of subsets) of  $\mathbf{R}^3$ .

where  $machinable(mf_k, type(q_k))$  returns true if machining feature  $mf_k$  can be machined by the type of machining operation  $q_k$  (denoted as  $type(q_k)$ ), and false otherwise.

- Finished new part must be functional:

$$functional(s_{0m_0}) = \text{true} \quad (4)$$

where  $functional(s_{0m_0})$  returns true if finished part geometry  $s_{0m_0}$  has all critical geometric features within the acceptable ranges, and false otherwise.

- Relocation is done by rigid body translation and/or rotation

$$r_{0j} \in TR; j = 1, 2, \dots, m_0 \quad (5)$$

where  $TR$  is a set of rigid body motions that yield a feasible fixturing configuration (e.g., translation and rotation at 90 degree increments).

- In-process geometry is fixturable at each process:

$$E_{0j}^{min} \subseteq r_{0j}(s_{0j-1}) \subseteq E_{0j}^{max}; j = 1, 2, \dots, m_0 \quad (6)$$

- Material is removed by machining at each process:

$$o_{0j}(r_{0j}(s_{0j-1})) \subset r_{0j}(s_{0j-1}); j = 1, 2, \dots, m_0 \quad (7)$$

In addition, any problem specific constraints, such as process capacity and prohibition to utilize certain existing processes, can be imposed and written in a generic form as

$$g(s_{00}, \mathbf{p}_0) = \text{true} \quad (8)$$

### 3.3 Definition of objective functions

The primary objective of DFEL is to obtain a modified part design  $s_{0m_0}$  and its process sequence  $\mathbf{p}_0 = \langle p_{01}, p_{02}, \dots, p_{0m_0} \rangle$  with the minimum length, which maximize the utilization of available manufacturing processes in the existing lines  $\mathbf{p}_1, \mathbf{p}_2, \dots, \mathbf{p}_n$ . These correspond to the following two objectives to be minimized (written in symbolic forms for simplicity):

- Number of new manufacturing operations in  $\mathbf{p}_0$  that do not match any operation in  $\mathbf{p}_1, \mathbf{p}_2, \dots, \mathbf{p}_n$ :

$$f_1 = \text{nomatch}(\mathbf{p}_0, \mathbf{p}_1, \mathbf{p}_2, \dots, \mathbf{p}_n) \\ = m_0 - \text{match}(\mathbf{p}_0, \mathbf{p}_1, \mathbf{p}_2, \dots, \mathbf{p}_n) \quad (9)$$

where the function  $match()$  returns the number of manufacturing operations on the line  $p_0$ , whose machines are picked from those available in the lines  $p_1, \dots, p_n$ . For a manufacturing operation to be considered a *match*, the machinery and fixturing must abide simultaneously to the in-progress part geometry manufacturing and size requirements.

- Number of manufacturing operations in  $\mathbf{p}_0$ :

$$f_2 = m_0 \quad (10)$$

Also, the addition of new material transfer lines should be avoided by minimizing the following objectives:

- Number of switching in  $\mathbf{p}_0$  among available manufacturing lines  $\mathbf{p}_1, \mathbf{p}_2, \dots, \mathbf{p}_n$ :

$$f_3 = \text{switch}(\mathbf{p}_0, \mathbf{p}_1, \mathbf{p}_2, \dots, \mathbf{p}_n) \quad (11)$$

- Number of manufacturing operations on the same line but out of sequence:

$$f_4 = \text{out-of-seq}(\mathbf{p}_0, \mathbf{p}_1, \mathbf{p}_2, \dots, \mathbf{p}_n) \quad (12)$$

Finally, unnecessary material waste should be avoided by minimizing the following objectives:

- Stock volume:

$$f_5 = \text{volume}(s_{00}) \quad (13)$$

- Volume to be machined from the stock:

$$f_6 = \text{volume}(s_{00}) - \text{volume}(s_{0m_0}) \quad (14)$$

Since a six-dimensional Pareto set is very difficult to interpret, the following case study aggregates some of these objectives as weighted sums, in order to reduce the dimension of the resulting Pareto set.

### 3.4 Optimization algorithm

Due to a combinatorial nature of the stated optimization problem and the existence of multiple objectives, a multi-objective genetic algorithm [26,27] is utilized, which can efficiently compute near-Pareto-optimal solutions of mixed discrete-continuous optimization problems. A variant of NSGA-II [26] is implemented for the following case study, which is outlined below:

- Create a population  $Q_{\text{main}}$  of  $n_q$  chromosomes (an encoded representation of the design variables) and evaluate their values of objective functions
- Rank each chromosome  $c$  in  $Q_{\text{main}}$  according to the number of other chromosomes dominating  $c$  (rank 0 is Pareto optimal in  $Q_{\text{main}}$ ). Store the chromosomes with rank 0 into set  $O$
- Create an empty sub-population  $Q_{\text{new}}$
- Select two chromosomes  $c_i$  and  $c_j$  in  $Q_{\text{main}}$
- Crossover  $c_i$  and  $c_j$  to generate two new chromosomes  $c_i'$  and  $c_j'$  with a certain high probability
- Mutate  $c_i'$  and  $c_j'$  with a certain low probability
- Evaluate the objective function values for  $c_i'$  and  $c_j'$  then store them in  $Q_{\text{new}}$ . If  $Q_{\text{new}}$  contains less than  $n_q$  new chromosomes, go to 4.
- Let  $Q_{\text{main}} \leftarrow Q_{\text{new}}$
- Delete  $Q_{\text{new}}$
- Update the set  $O$  and increment the generation counter. If the generation counter has reached a pre-specified number, terminate the process and return  $O$ . Otherwise go to 3

Fig. 6 shows a schematic of the chromosome that encodes the design variables  $m_0, e, q$ , and  $s_{00}$  described in Section 3.2. It is simply a concatenation of  $m_0, e, q$ , and the part dimensions to represent  $s_{00}$ , with slack locations for  $e$  and  $q$  to allow the variations in length up to  $m_{\text{max}}$ , an upper bound of  $m_0$ . Each segment of the chromosomes is subject to the following crossover and mutation operators:

- $m_0$  segment: no crossover or mutation.
- $e$  segment: substring swap and path re-linking [27, 28], known as effective for variable-length permutations.
- $q$  segment: uniform crossover [28] with random mutation.
- $s_{00}$  segment: heuristic and arithmetic crossovers [28] with random mutation.

Upon the termination of a GA run at step 10, set  $O$  contains near Pareto optimal solutions. For each of these Pareto solutions, a local optimization is performed by examining the one-swap neighborhood of  $e$ , followed by gradient search along the continuous dimensions for  $s_{00}$ , while keeping the discrete variables constant. The new solution replaces the old one only if the former dominates the latter.

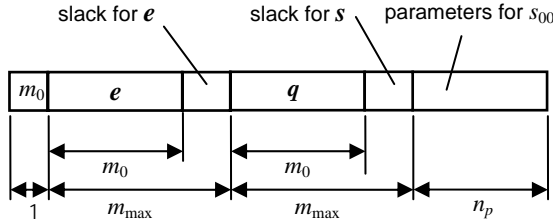
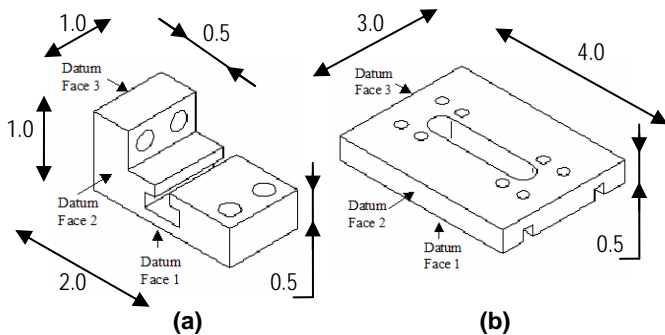

**Fig. 6. Encoding of the design variables in a chromosome. Slacks for  $e$  and  $s$  are to accommodate their variations in length as specified by the value of  $m_0$ .**

#### 4. CASE STUDY: MACHINE BRACKET

##### 4.1 Problem

This section describes a case study on the production of a new machine bracket considering two available production lines  $p_1$  and  $p_2$  (i.e.,  $n = 2$ ) considering products A and B, respectively. The shape and main dimensions of products A and B are shown in Fig. 7. Both products are machined from a rectangular block. Tables 1 and 2 list the information on the machining operations in  $p_1$  and  $p_2$ , respectively, where type  $fm$ ,  $em$ , and  $d$  denote face milling, end milling, and drilling, respectively.



**Fig. 7. Products with existing production lines: (a) product A and (b) product B. All specified dimensions are in inches.**

Fig. 8 shows the shape and main dimensions of the new part to be introduced. Assuming that the new product is machined from an L-shaped stock, dimensions  $L_1$  through  $L_5$  are adopted as the parameters to describe the stock geometry  $s_{00}$ . Table 3 shows the 7 critical design features of the new product. Assuming exactly one machining operation is required to complete each design feature, the features in Table 3 can also be regarded as the minimally-required machining features in  $MF$ . Table 3 also lists the compatible operation types, for which *machinable* in Eq. (3) is true. Among the machining features in

Table 3, the datum faces 1-3 must be machined before the other features, namely:

$$mf_1, mf_2, mf_3 \prec mf_4, mf_5, mf_6, mf_7 \quad (15)$$

There is no other precedence assumed among the machining features.

**Table 1. Machining operations for existing product A, where  $fm$  = face milling,  $em$  = end milling,  $d-2$  = drilling 2 holes.**

operation	type	feature	$E^{min}$ [in]	$E^{max}$ [in]
$p_{11}$	$fm$	datum 1	1.0×2.2	2.0×3.3
$p_{12}$	$fm$	datum 2	1.0×2.2	2.0×3.3
$p_{13}$	$fm$	datum 3	0.875×1.125	0.875×1.125
$p_{14}$	$fm$	L-shape	1.2×2.2	2.3×3.3
$p_{15}$	$em$	middle slot	1.2×2.2	2.3×3.3
$p_{16}$	$em$	T-slot	1.2×2.2	2.3×3.3
$p_{17}$	$d-2$	hole set 1	1.2×2.2	2.3×3.3
$p_{18}$	$d-2$	hole set 2	0.875×1.125	0.875×1.125

**Table 2. Machining operations for existing product B, where  $fm$  = face milling,  $em-2$  = end milling 2 slots,  $em$  = end milling,  $d-4$  = drilling 4 holes, and  $d-2$  = drilling 2 holes.**

operation	type	feature	$E^{min}$ [in]	$E^{max}$ [in]
$p_{21}$	$fm$	datum 1	2.25×3.25	3.2×4.2
$p_{22}$	$fm$	datum 2	0.25×1.2	3.0×4.2
$p_{23}$	$fm$	datum 3	0.25×1.2	3.0×4.2
$p_{24}$	$em-2$	bottom slot	2.25×3.25	3.2×4.2
$p_{25}$	$em$	center slot	2.25×3.25	3.2×4.2
$p_{26}$	$d-4$	hole set 1	2.25×3.25	3.2×4.2
$p_{27}$	$d-4$	hole set 2	2.25×3.25	3.2×4.2

Table 4 shows the acceptable ranges of  $L_1$  through  $L_5$  along with their current values. Since dimensions  $L_1$  through  $L_5$  of the L-stock may be larger than the acceptable range in Table 4 of the finished part, it is assumed there can be up to 3 additional face milling operations for each dimensions  $L_1$  through  $L_5$  for size reduction. Since  $l = 7$ , this yields  $m_{max} = 7 + 3 \times 5 = 22$ .

To facilitate the interpretation of the resulting Pareto-optimal solutions, the six objectives of Eqn. 9 through Eqn. 14 are aggregated into three objective functions, all to be minimized:

$$f_1' = w_1 f_1 \quad (14)$$

$$f_2' = w_2 f_2 + w_3 f_3 + w_4 f_4 \quad (15)$$

$$f_3' = w_5 f_5 + w_6 f_6 \quad (16)$$

where  $w_i, i = 1, 2, \dots, 6$  are weights. All original objectives  $f_1, \dots, f_6$  are assumed as equally important, and therefore the weights are simply scaling factors such that the added terms have same order of magnitude. If an accurate process cost model exists, these weights can be selected to reflect their relative importance.

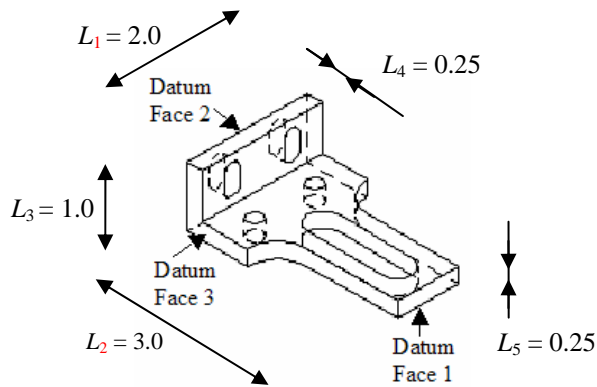

Fig. 8. Shape and main dimensions of the new product. All specified dimensions are in inches.

Table 3. Critical design features of the new part, each of which corresponds to the minimally-required machining feature  $mf_i$ , and the compatible operation types.

feature id	name	machinable operation type
1	datum-1	$fm$
2	datum-2	$fm$
3	datum-3	$fm$
4	middle slot	$em$
5	face slots	$em-2$
6	side profile	$em$
7	hole set	$d-2$

Table 4. Dimensions of the new part in Fig. 8 and their acceptable ranges

dimension	value [in]	min [in]	max [in]
$L_1$	2.00	2.00	2.500
$L_2$	3.00	3.00	3.500
$L_3$	1.00	1.00	1.500
$L_4$	0.25	0.25	0.375
$L_5$	0.25	0.25	0.375

#### 4.2 Results and discussion

Being a stochastic search algorithm, the results produced by GA are typically slightly different every time it is run. It is therefore a common practice to perform several runs for each considered problem. In this study, 10 GA runs were performed. All runs used an overall crossover probability of 0.9 and mutation of 0.1. The population size and number of generations are listed in Table 5. It is noted that the total number of model simulations for all the runs combined, is only a very tiny fraction of the search space, whose size is in the order of  $22! \times 15^{22}$  for discrete variables.

Fig. 9 shows the Pareto solutions obtained by combining the results of all 10 GA runs (indicated with filled circles), and their improvements via the subsequent local search (indicated

with filled squares). In Fig. 9 objectives  $f_1'$ ,  $f_2'$  and  $f_3'$  are normalized to the interval of [0, 1].

Table 5. Parameters for genetic algorithm for different runs

Run ID	Population size	Number of Generations	Number of Model Simulations
1, 2	400	50	20,000
3, 4	200	80	16,000
5, 6	150	120	18,000
7, 8	200	150	30,000
9, 10	400	100	40,000

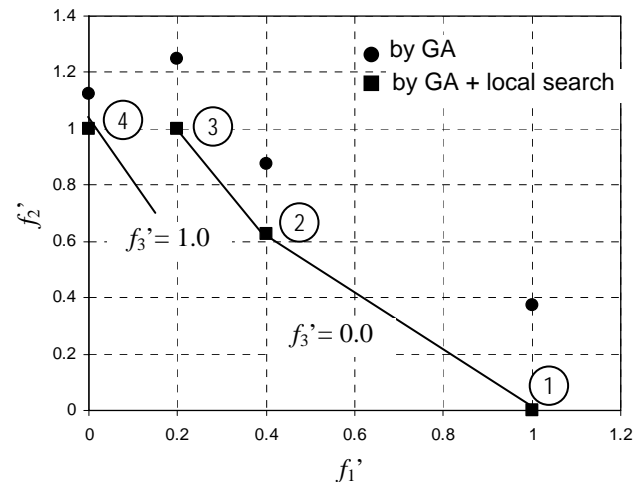

Fig. 9. The solution by 10 GA runs (circles) and their improvements via the subsequent local search (squares). All objectives are normalized to the interval of [0,1].

Table 6 lists the solutions 1-4 labeled in Fig 9, obtained by GA and local search. All solutions have the smallest possible number of operations ( $m_0 = l = 7$ ). No design modification was made in solutions 1-3, whereas  $L_1$  and  $L_2$  are made slightly larger in solution 4:

- Solution 1 uses new operations for all machining features (hence worst in  $f_1'$ ), which allows the use of a minimal size stock with no jumps between production lines or out of sequence steps (hence best in  $f_2'$ ).
- Solutions 2 and 3 also use a minimal size stock, and make use of some of the existing manufacturing operations. The consequently, there is one line jump in solutions 2 (from  $p_0$  to  $p_1$ ), and two line jumps in solution 3 (from  $p_2$  to  $p_0$ , and from  $p_0$  to  $p_1$ ).
- Solution 4 realizes a maximum number of existing operations among all, by taking advantage of fixturing features: Larger  $L_1$  and  $L_2$  in the starting stock allow the in-process part geometry to be fixturable at operation  $p_{23}$ . Consequently, the final part is larger than the initial design. It is, however, considered functional since all dimensions fall within the acceptable ranges in Table 4.

It is noted that size reduction of to the original dimensions could have been achieved in solution 4 by adding one (or two) more manufacturing processes at the end of the line. While doing so would improve  $f_3'$  (stock and machined volumes), it would add too much penalty on  $f_2'$  (extra process and out of sequence step), resulting in the domination by solution 2.

## 5. CONCLUSION AND FUTURE WORK

This paper presented a new design method, Design for Existing Lines (DFEL), to reduce the cost of introducing a new product into the market via the effective utilization of existing production facilities. The method takes as inputs a nominal part design and the process information of the existing lines, and produces alternative product designs and process plans with a multi-objective genetic algorithm. A case study on a new machine bracket considering two existing production lines demonstrated a success in efficiently generating alternative product and process designs with varying utilization of existing processes.

Future work would include case studies on more complex parts and the method application to assemblies, additional analysis of process sharing, machine capacity, and production cost. Future work could also include consideration of part deformation under the manufacturing and fixturing loads, exploration of part deformation, net shape and material adding manufacturing processes, as well as consideration of partial reconfiguration of machines and/or fixtures in the existing production lines.

**Table 6. Solutions 1-4 in Fig. 9**

	Solution 1	Solution 2	Solution 3	Solution 4
$f_1'$	1.000	0.400	0.200	0.000
$f_2'$	0.000	0.625	1.000	1.000
$f_3'$	0.000	0.000	0.000	1.000
$L_1$	3.00	3.00	3.00	3.25
$L_2$	2.00	2.00	2.00	2.25
$L_3$	1.00	1.00	1.00	1.00
$L_4$	0.25	0.25	0.25	0.25
$L_5$	0.25	0.25	0.25	0.25
$m_0$	7	7	7	7
$e$	1,2,3,4,5,6,7	1,2,3,6,4,5,7	3,2,1,4,5,6,7	1,2,3,4,5,6,7
$p_{01}$	(new)	(new)	$p_{22}$	(new)
$p_{02}$	(new)	(new)	(new)	(new)
$p_{03}$	(new)	(new)	(new)	$p_{23}$
$p_{04}$	(new)	(new)	(new)	$p_{24}$
$p_{05}$	(new)	$p_{15}$	$p_{15}$	$p_{15}$
$p_{06}$	(new)	$p_{16}$	$p_{16}$	$p_{16}$
$p_{07}$	(new)	$p_{17}$	$p_{17}$	$p_{17}$

## REFERENCES

[1] MacDuffie, J.P., 1991, *Beyond Mass Production: Flexible Production Systems and Manufacturing Performance in the World Auto Industry*, Ph. D. Dissertation, Sloan School of Management, M.I.T.

[2] Manson, F., 1995, "High volume learns to flex," *Manufacturing Engineering*, November 1995, pp 53-59.

[3] Shah, J. J. and Wright, P. K., 2000, "Developing theoretical foundations of DfM," *Proceedings of the 2000 ASME Design Engineering Technical Conferences*, September 10-14, Baltimore, MD, DETC2000/DFM-14015.

[4] van Vliet, J. W., van Luttervelt, C. A., and Kals, H. J. J., 1999, "State-of-the-art report on design for manufacturing," *Proceedings of the 1999 ASME Design Engineering Technical Conferences*, September 12-13, Las Vegas, Nevada, DETC99/DFM-8970.

[5] Bralla, J. G., 1999, *Design for Manufacturability Handbook*, Second Edition, McGraw-Hill, 11 West 19th Street, New York, NY 10011.

[6] Boothroyd, G. and Dewhurst, P., 1987, *Product Design for Assembly*, Boothroyd Dewhurst, Inc., 2 Holley Road, Wakefield, RI 02879.

[7] Taylor, G. D., English, J. R., and Graves, R. J., 1994, "Designing new products; compatibility with existing product facilities and anticipated product mix," *Integrated Manufacturing Systems*, Vol. 5, pp 13-21.

[8] Herrmann, J. W. and Chincholkar, M. M., 2000, "Design for production: a tool for reducing manufacturing cycle time," *Proceedings of the 2000 ASME Design Engineering Technical Conference*, September 10-13, Baltimore, Maryland, DETC2000/DFM-14002.

[9] Brissaud, D., Paris, H., and Tichkiewitch, S., 1997, "Assisting designers in the forecasting of surfaces used for easier fixturing in a machining process," *Journal of Materials Processing Technology*, Vol. 65, pp 26-33.

[10] Coope, R. L., 1993, "Modular fixturing vs. dedicated tooling – the pros and cons," *SME Technical Paper*, TE93-388.

[11] Kakish, J., Zhang, P., and Zeid, I., 2000, "Towards the design and development of a knowledge-based universal modular jigs and fixtures systems," *Journal of Intelligent Manufacturing*, Vol. 11, pp 381-401.

[12] Sarma, S. E. and Wright, P. K., 1997, "Reference free part encapsulation: a new universal fixturing concept," *Journal of Manufacturing Systems*, Vol. 16, No. 1, pp 35-47.

[13] Sarma, S. E. and Wright, P. K., 1998, "Using mechanical hardware to simplify process planning," *Computer Integrated Manufacturing Systems*, Vol. 11, No. 3, pp147-155.

[14] Escoto, R. P., McDonnell, L. R., Vicens S. E., and Lario E. F. C., 1998, "Development of an algorithm for the application of group technology in the design of manufacturing systems," *Production Planning and Control*, Vol. 9, No. 3, pp 267-274.

[15] Kamel, M., Ghenniwa, H., and Liu, T., 1994 "Machine assignment and part-families formation using group technology," *Journal of Intelligent Manufacturing*, Vol. 5, No. 4, pp 225-237.

[16] Kamrani, A. K., Agarwal, A., and Parsari, H., 1994, "Automated Coding & Classifications Systems with Supporting Databases for Effective Design of Integrated Manufacturing Systems," The special Issue of the *Intelligent Manufacturing Systems*, Environmental and

- Intelligent Manufacturing Systems Series, Prentice Hall, Upper Saddle River, NJ 07458.
- [17] Kao, Y. and Moon, Y. B., 1998, "Feature-based memory association for group technology," *International Journal of Production Research*, Vol. 36, No. 6, pp 1653-1677.
  - [18] Xu, H. and Wang, H., 1989, "Part family formation for GT applications based on fuzzy mathematics," *International Journal of Production Research*, Vol. 27, No. 9, pp 1637-1651.
  - [19] Chang, T. C. and Wysk, R. A., 1985, *An Introduction to Automated Process Planning Systems*, Prentice Hall, Englewood Cliffs, NJ 07460.
  - [20] Gupta, S. K., Regli, W. C., Das, D., and Nau, D. S., 1997, "Automated manufacturability analysis: A survey," *Research in Engineering Design*, Vol. 9, pp 168-190.
  - [21] Kamrani, A. K., 1996, "An integrated knowledge-based system for product design feasibility and manufacturability analysis," *Computers in Industrial Engineering*, Vol. 31, No. ½, pp 83-86.
  - [22] Paris, H. and Brissaud, D., 2000, "Modelling for process planning: the links between process planning entities," *Robotics and Computer Integrated Manufacturing*, Vol. 16, pp 259-266.
  - [23] Shah, J. J., 1992, "Features in Design and Manufacturing," *Intelligent Design and Manufacturing*, Kusiak, A. ed., John Wiley and Sons, NJ.
  - [24] Brissaud, D. and Tichkiewitch, S., 2000, "Innovation and manufacturability analysis in an integrated design context," *Computers in Industry*, Vol. 43, pp 111-121.
  - [25] Qureshi, K. and Saitou, K., 2002, "Design for Fixturability (DFF) Methodology for Commodity Parts: A Case Study with Connecting Rod Designs," *Journal of Computing and Information Science in Engineering*, Vol. 2, No. 1, pp. 21-27.
  - [26] Deb, K., Agrawal, S., Pratab, A., and Meyerivan, T., 2000, "A fast elitist non-dominated sorting genetic algorithm for multi-objective optimization: NSGA-II," *Proceedings of the Parallel Problem Solving from Nature VI*, Paris, France, pp. 849-858.
  - [27] Coello, C. A., Veldhuizen, D. A., and Lamont, G. D., 2002, *Evolutionary Algorithms for Solving Multi-Objective Problems*, Kluwer Academic/Plenum Publishers, , London, UK.
  - [28] Michalewicz, Z., 1994, *Genetic Algorithms + Data Structures = Evolution Programs*. 3<sup>rd</sup> Edition, Springer-Verlag, Berlin.