



How Similar or Different is Mathematics Teaching Across K-12? How Might Mathematics Instruction Be Improved?

Deborah Loewenberg Ball

Western Massachusetts Mathematics Partnership

September 17, 2011

SCHOOL OF EDUCATION **M** UNIVERSITY OF MICHIGAN

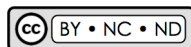

This work is licensed under the Creative Commons Attribution-NonCommercial-No Derivative Works
Version 3.0 United States License: <http://creativecommons.org/licenses/by-nc-nd/3.0/us/>

© 2011 Mathematics Teaching and Learning to Teach • School of Education • University of Michigan • Ann Arbor, MI 48109 • mtlt@umich.edu

Overview of session

1. Mathematics teaching, and instructional improvement, in a broader context
2. Three resources for improving mathematics instruction:
 - High-leverage practices of teaching
 - High-leverage content knowledge for teaching
 - Practice-based common work on teaching

I. MATHEMATICS TEACHING, AND ITS IMPROVEMENT, IN CONTEXT

Context for video

- Fifth grade permutations problem:

How many different three-digit numbers can you make using the digits 1, 2, and 3, and using each digit only once.

Show all the three-digit numbers that you found.

How do you know that you found them all?

- 28 students, summer “turnaround” math program
- Come from different schools in fourth grade, performing below grade level
- Latino, White, African-American, Chinese, Arab

Viewing focus

1. What mathematics *learning* opportunities can you see?
2. What can you identify about the work of *teaching* mathematics?

Elementary and secondary teaching of mathematics

How are they different?

- Striving to express ideas efficiently is more a goal at secondary
- Range of student capabilities may grow as students get older
- How much of the learning is supposed to happen outside the class (more at college)

How are they the same?

- Focus on student thinking
- Help students understand abstract concepts
- Focus on problem solving (may be more concrete at one level than the other)
- Differentiation
- Leading discussions of mathematics
- Help students make connections between old and new thinking
- Level of mathematics differs, but the mathematical subject matter is the same in many ways

Teachers matter—a lot

- Differences in teachers account for 12%-14% of total variability in students' mathematical achievement in each of grades 1, 2, and 3.
- Students assigned to three effective teachers in a row score at the 83rd percentile in math at the end of 5th grade; children assigned to three ineffective teachers in a row score only at the 29th percentile.
- The cumulative effects of being taught by a highly effective teacher can substantially reduce differences in student achievement that are due to family background.

A basic conception of the work of teaching

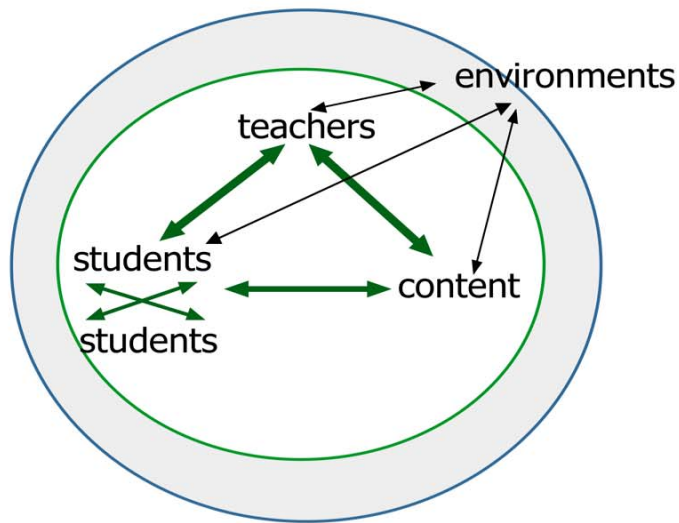

Taking active responsibility for:

1. deliberately maximizing the quality of the interactions . . .
2. . . . in ways that maximize the probability that students learn
3. . . . worthwhile content and skills

Two schools of thought, or bets

1. Focus on teachers

- recruitment, selection
- rewards and sanctions

2. Focus on teaching

- training
- assessment
- curriculum

What are the reasons to bet more on one or the other?

Why the problem is one of professional training

- The scale of the need
- Teaching as unnatural, intricate, and deliberate work

The realities of scale

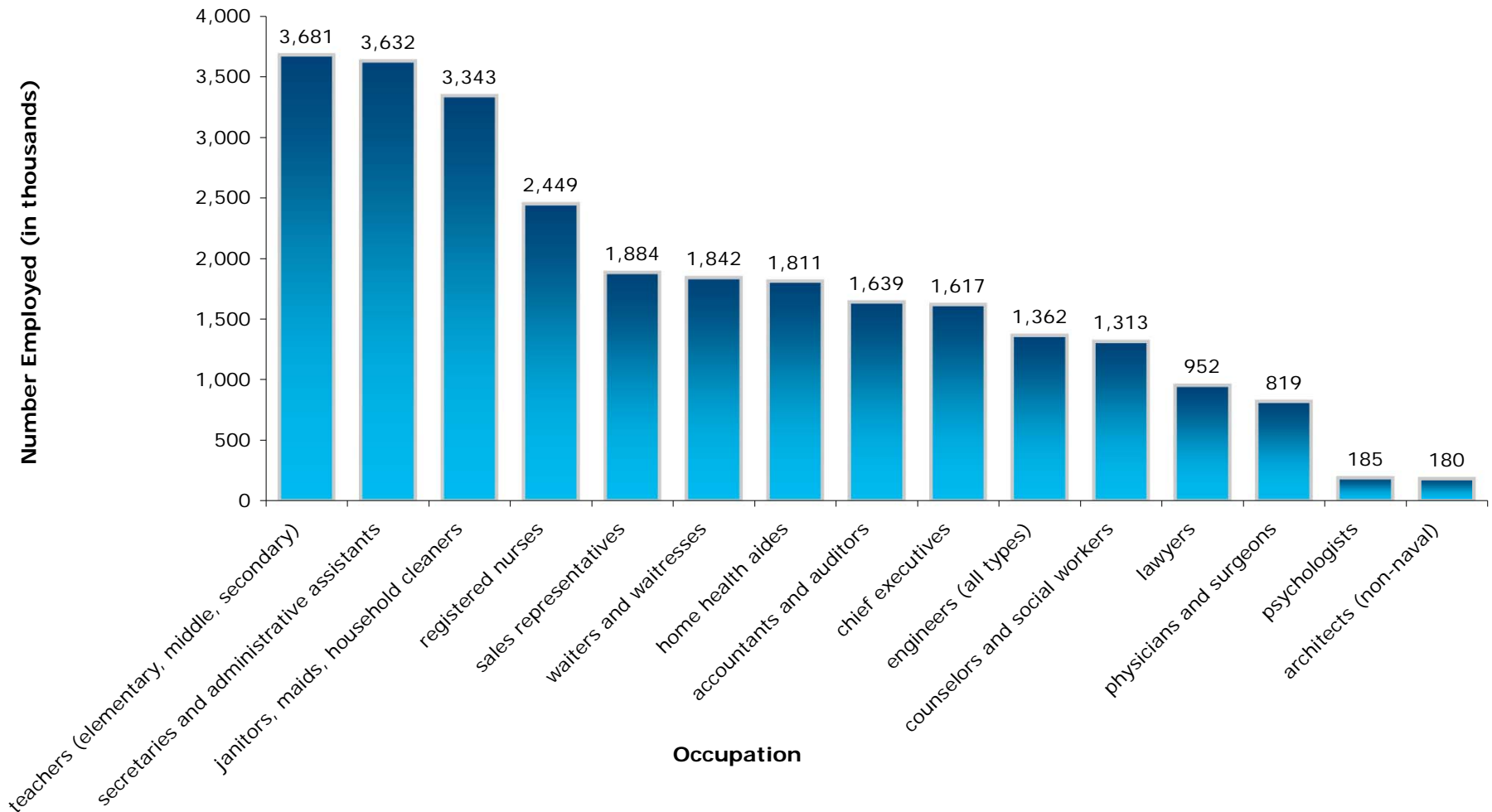

Teaching mathematics as a specialized form of mathematical work

You ask your students to explain what a rectangle is. One offers a definition:

A rectangle is a flat shape. It has four square corners, and it is closed all the way around.

What is the work for the teacher?

A rectangle is a flat shape. It has four square corners, and it is closed all the way around.

1. To see that something is missing
2. Decide what to do or say
3. Offer a non-rectangle that meets the proposed definition

“Is this a rectangle?”

What is a shape that satisfies this definition and yet is not a rectangle?

What is the work for the teacher?

A rectangle is a flat shape. It has four square corners, and it is closed all the way around.

1. To see that something is missing
2. Decide what to do or say
3. Offer a non-rectangle that meets the proposed definition

“Is this a rectangle?”

(straight sides)

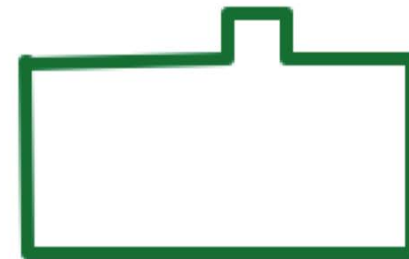

(exactly four square corners)

A rectangle is a flat shape with **straight sides that are connected at exactly** four square corners. It is closed all the way around.

Teaching involves special kinds of mathematical work

1. Solving special kinds of mathematical problems
2. Engaging in specialized mathematical reasoning
3. Using mathematical language precisely but accessibly

Analyzing — and “talking” — representations

Which of these can be used to represent $\frac{5}{6} \div \frac{1}{3}$?

Explain with reference to all parts of the expression.

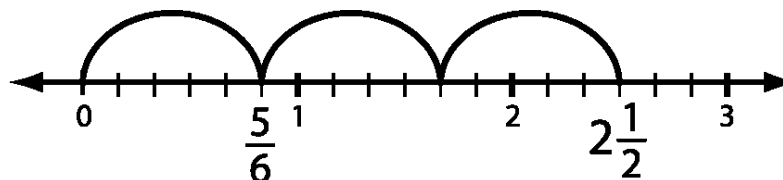
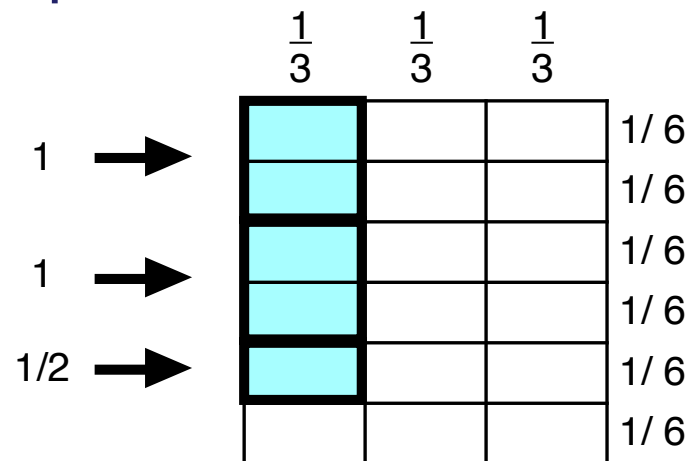
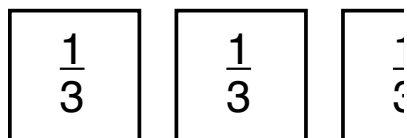
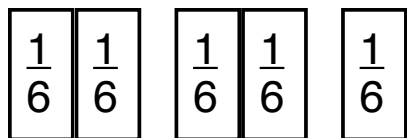
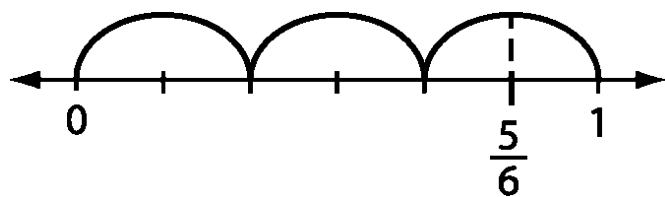

Analyzing errors

What mathematical steps could have produced this answer?

(a)

$$\begin{array}{r} 49 \\ \times 25 \\ \hline 405 \\ 108 \\ \hline 1485 \end{array}$$

(b)

$$\begin{array}{r} 49 \\ \times 25 \\ \hline 225 \\ 100 \\ \hline 325 \end{array}$$

(c)

$$\begin{array}{r} 49 \\ \times 25 \\ \hline 1250 \\ 25 \\ \hline 1275 \end{array}$$

Determining whether students understand

$$\begin{array}{r} | \\ 15 \\ 29 \\ +12 \\ \hline 54 \end{array}$$

Determining whether students understand

$$\begin{array}{r} | \\ 15 \\ 29 \\ +12 \\ \hline 56 \end{array}$$

$$\begin{array}{r} | \\ 18 \\ 29 \\ +17 \\ \hline 54 \end{array}$$

Defining terms

- a) An even number is a number that can be divided into two equal parts.
- b) An even number is any multiple of 2.
- c) An even number is any integer multiple of 2.
- d) An even number is any number whose unit digit is 0, 2, 4, 6, or 8.
- e) A whole number is even if it is the sum of a whole number with itself.

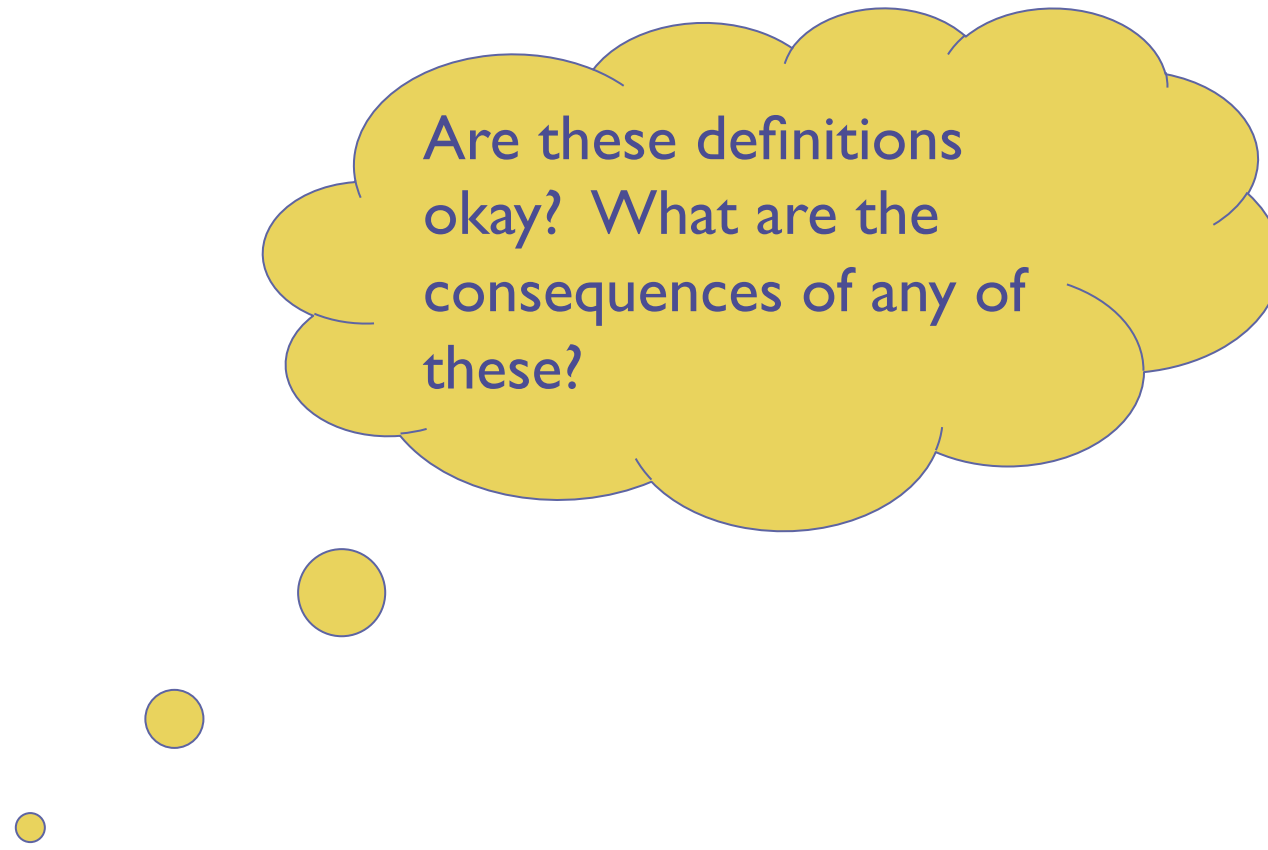

Are these definitions okay? What are the consequences of any of these?

a) An even number is a number that can be divided into two equal parts.

b) An even number is any multiple of 2.

All numbers, for example 7, $3/5$, $\sqrt{2}$, π , are even!

c) An even number is any integer multiple of 2.

This is a correct definition of even number.

d) An even number is any number whose unit digit is 0, 2, 4, 6, or 8.

In this case, 36.7 is an even number!

e) A whole number is even if it is the sum of a whole number with itself.

This is a correct definition of evenness for whole numbers, and is consistent with the general definition for integers that will arrive later.

Posing mathematics problems

POSSIBLE PROBLEM:

I have pennies, nickels, and dimes in my pocket. If I pull out two coins, what amounts of money might I have?

Reasoning about different wording

How does the exact wording of the problem affect the mathematical work for my students? Which best fits my goals for them?

Reasoning about different wording

1. I have pennies, nickels, and dimes in my pocket. If I pull out two coins, what amount of money might I have?
2. I have pennies, nickels, and dimes in my pocket. If I pull out two coins, how many combinations are possible?
3. I have pennies, nickels, and dimes in my pocket. If I pull out two coins, how many different amounts of money are possible? Prove that you have found all the amounts that are possible.

Teaching involves special kinds of mathematical work

1. Solving special kinds of mathematical problems
2. Engaging in specialized mathematical reasoning
3. Using mathematical language precisely but accessibly

Teaching involves specialized mathematical work

Solving special kinds of mathematical problems	Engaging in specialized mathematical reasoning	Using mathematical language precisely but accessibly
<ul style="list-style-type: none"> • Selecting or constructing a strategic example, representation, or task • Analyzing representations and definitions • Analyzing non-standard correct responses and incorrect responses 	<ul style="list-style-type: none"> • Comparing mathematical alternatives • Justifying choices of representations, language, and tasks • Reasoning about starting points and sequences 	<ul style="list-style-type: none"> • Coordinating between mathematical details and precision and terms children know or can learn to use • Coordinating between simple, invented, or everyday language and mathematical details • Judging what can be left more casual and what not

What makes this specialized mathematical work?

1. It is a doing of math conditioned by its ultimate uses.
2. It is not pedagogy—there is much more to teaching than this.
3. It is math, but performed in the service of helping others learn mathematics.

What kinds of “knowing” and using mathematics are entailed by the specialized mathematical work of teaching?

Mathematical Knowledge for Teaching (MKT)

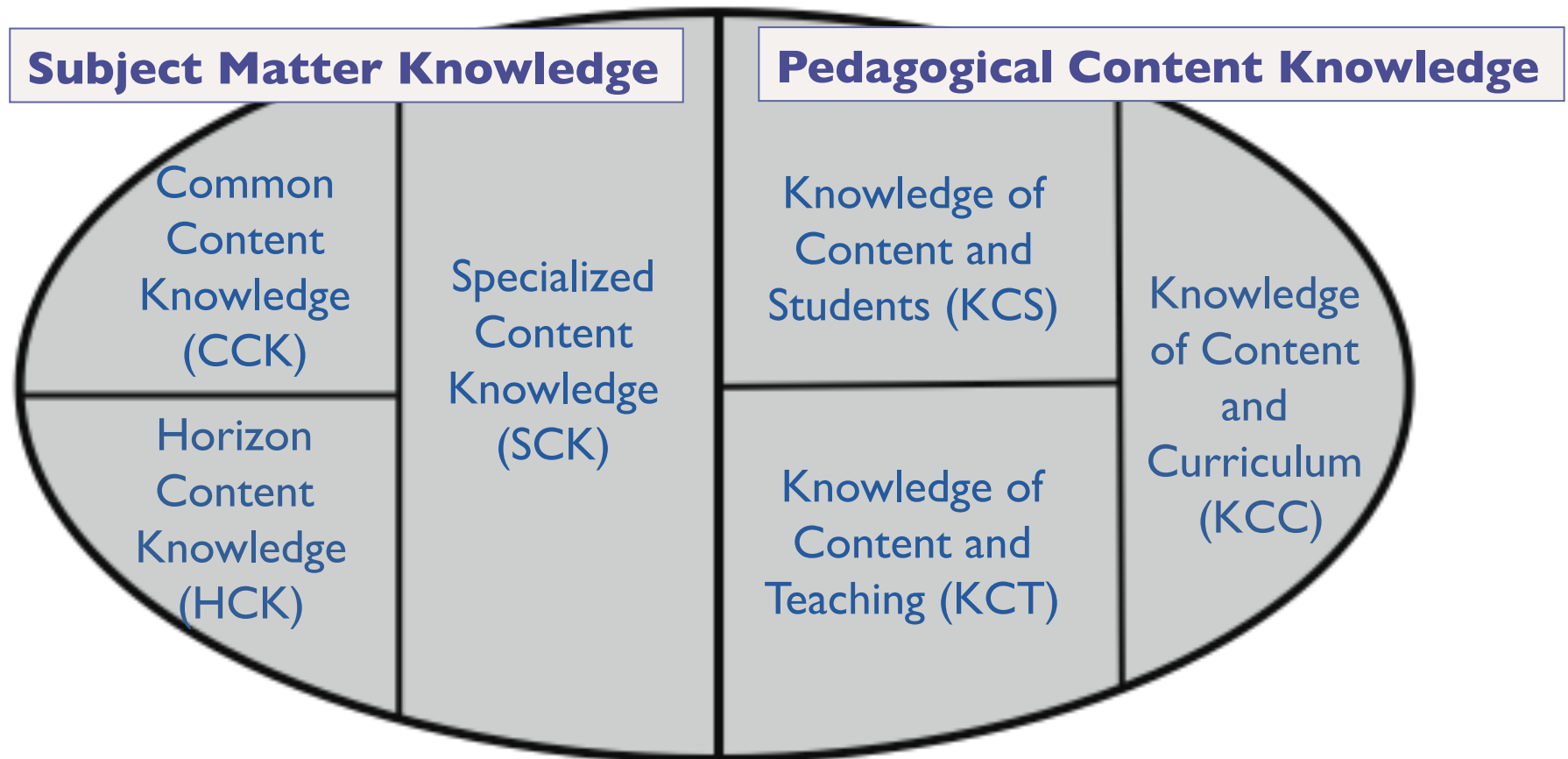

What is MKT not?

1. It is not just knowing the topics of the school curriculum.
2. It is not knowing school content from an “advanced perspective.”
3. It is not just another term for pedagogical content knowledge.
4. It is not being able to teach the content.

What is MKT?

1. Knowing mathematics from the perspective of helping others learn it.
2. Being mathematically ready to teach an idea, method, or other aspect of maths.

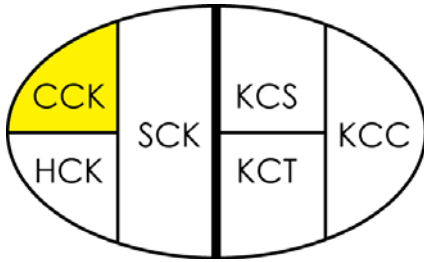

Common content knowledge (CCK)

Draw a **rectangle**.



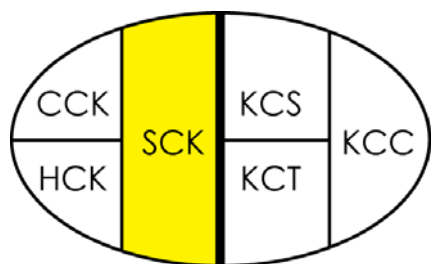

Specialized content knowledge (SCK)

Which of these figures would be good to present to assess whether students understand what a rectangle is, and why?

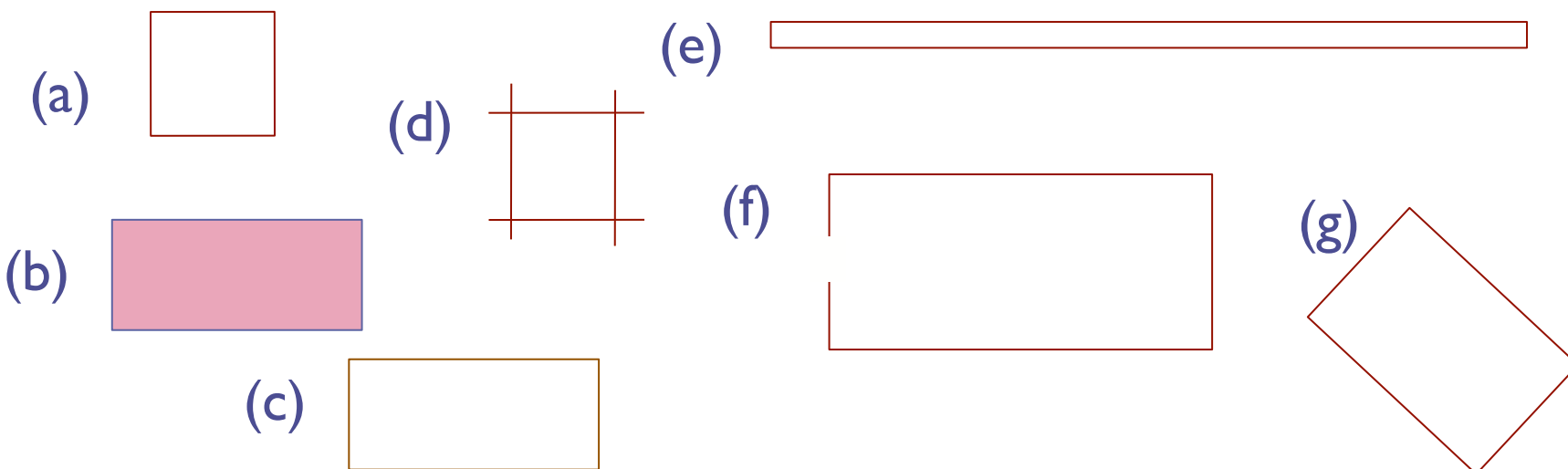

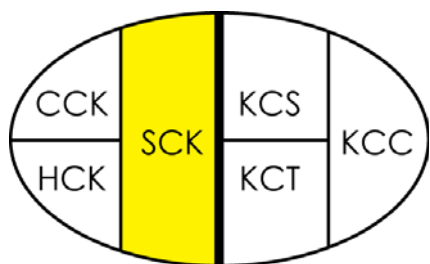

Specialized content knowledge (SCK)

Which of these is a mathematically accurate definition of “rectangle”?

- ① A rectangle is a figure with four straight sides, two long and two shorter.
- ② A rectangle is a shape with exactly four connected straight line segments meeting at right angles.
- ③ A rectangle is flat, and has four straight line segments, four square corners, and it is closed all the way around.

For any that are not mathematically accurate, give an example that shows what is wrong.

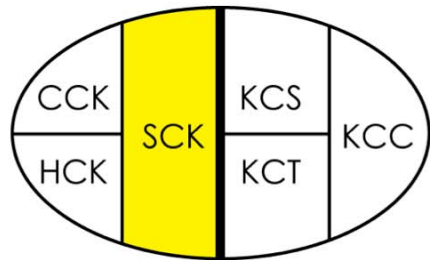

Specialized content knowledge (SCK)

- ① A rectangle is a figure with four straight sides, two long and two shorter.
- ② A rectangle is a shape with exactly four connected straight line segments meeting at right angles.
- ③ A rectangle is flat, and has four straight line segments, four square corners, and it is closed all the way around.



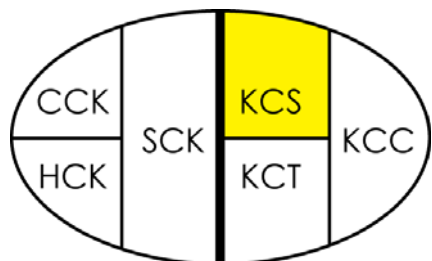

Knowledge of content and students (KCS)

- Write a mathematically accurate definition of “rectangle” that is usable by second graders.
- How can the notion of “simple closed curve” be expressed in a way that is both mathematically accurate and usable? Which part of this phrase is most challenging for children?

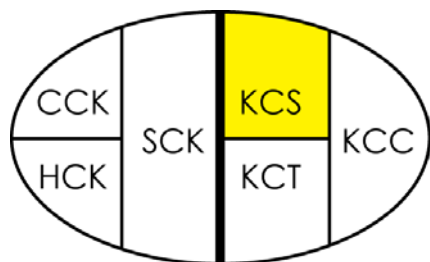

Knowledge of content and students (KCS)

- What are students likely to know about what a rectangle is?
- What do students typically have difficulty with in learning about rectangles, and why?

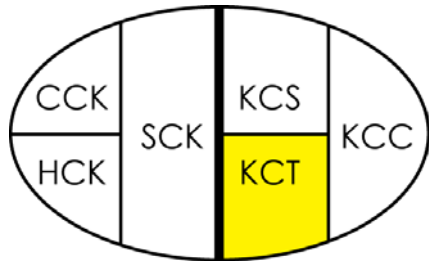

Knowledge of teaching and content (KCT)

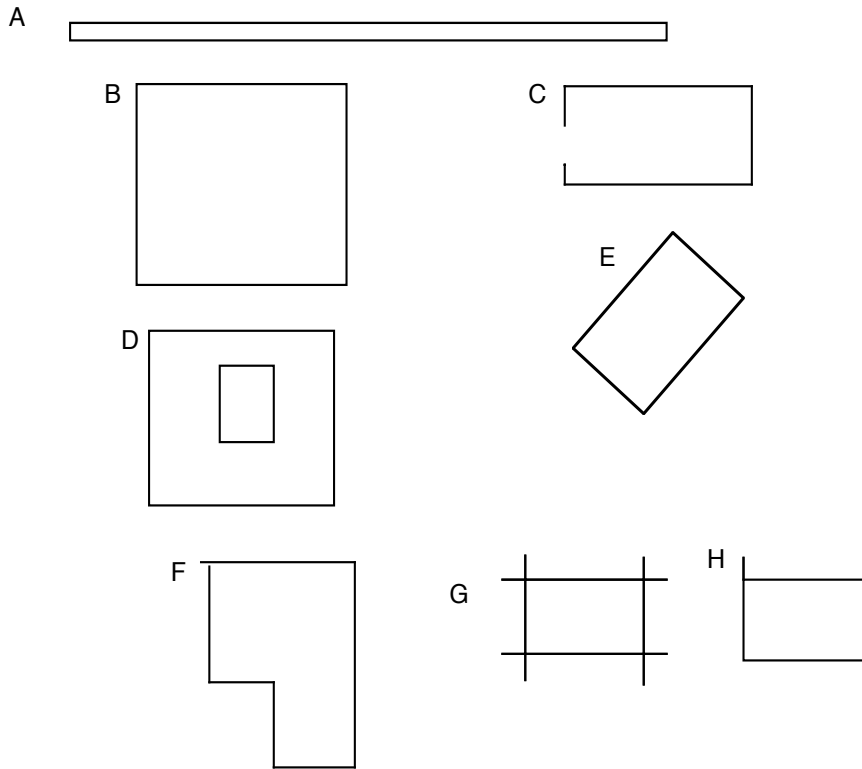

- How would you sequence these figures to discuss the concept of a rectangle?
- What task would you create using these figures (or others) to set up a productive discussion aimed at developing a definition?
- In a whole-class discussion, which one would be good to discuss first?

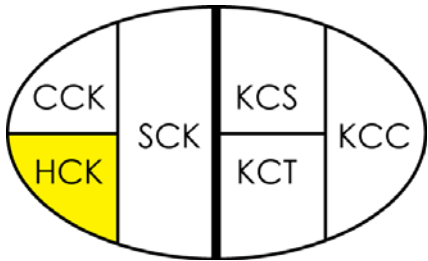

Horizon content knowledge (HCK)

- Is it okay to shade in the figures shown to students – e.g., 
- What are the issues involved with the fact that children learn about rectangles before polygons?

2. THREE RESOURCES FOR IMPROVING MATHEMATICS INSTRUCTION

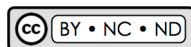

Three resources for responsible mathematics teaching

1. High-leverage practices of teaching
2. High-leverage content knowledge for teaching
3. Practice-based common work on teaching

High-leverage practices and high-leverage content

- High-leverage practices are instructional tasks and activities that powerfully promote student learning and are fundamental to competent teaching
- High-leverage content is those topics, practices, ideas, and texts that are foundational to the K-12 curriculum, including the Common Core, and essential for teachers to understand and be able to teach.

Examples of high-leverage instructional practices

- Explaining specific content ideas and processes
- Choosing and using representations, examples, and models of core content
- Giving oral and written feedback
- Recognizing and identifying common patterns of student thinking in a topic domain
- Selecting and using specific methods to assess students' learning on an ongoing basis
- Conducting a meeting with a parent or caregiver

High-leverage mathematical content for teaching

Mathematical content that:

- Forms an essential component of the curriculum at a particular grade level
- Is fundamentally connected across grades
- With which students often have difficulty
- Teachers may have learned only enough to do it themselves, but not unpack it

A second component: The CCSS mathematical practices

MP.1. Make sense of problems and persevere in solving them.

MP.2. Reason abstractly and quantitatively.

MP.3. Construct viable arguments and critique the reasoning of others.

MP.4. Model with mathematics.

MP.5. Use appropriate tools strategically.

MP.6. Attend to precision.

MP.7. Look for and make use of structure.

MP.8. Look for and express regularity in repeated reasoning.

No reliable *system* for preparing and developing teachers in the U.S.

- No common curriculum for teacher education — specific, professionally-agreed upon learning objectives for new or practicing teachers
- Over 2,500 independent providers of initial teacher training; over 2,000 curricula; even more diffuse for continuing professional education
- No common standard of performance for independent practice with (on) young people
- Teachers report doing most of their learning on the job

Practice-based common work on teaching

- Teaching mathematics as a specialized kind of mathematical work
- Teaching as intricate and deliberate, and not mostly idiosyncratic and “artistic”
- Building common protocols, cases, language for practice

The challenge

To UNLEARN:

1. a cultural conception of teaching as a personal and individual practice

- apprenticeship of observation, formal curriculum, mediated entry, on-the-job learning (Dan Lortie)
- Learning from one's own experience
- Teaching as highly contextualized and particular

... that reinforces the emphasis on the **person** in teaching, rather than the **practice**, and supports

2. an approach to supporting the development of practice that is also local and idiosyncratic

- No shared artifacts, cases, protocols, or language for either teaching or “teacher education”
- No common curriculum, and no consensus about learning goals, for either students or teachers

THANK YOU!

Slides will be available
at Deborah Ball's website

(Google "Deborah Ball")

SCHOOL OF EDUCATION  UNIVERSITY OF MICHIGAN

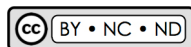

This work is licensed under the Creative Commons Attribution-Noncommercial-No Derivative Works
Version 3.0 United States License: <http://creativecommons.org/licenses/by-nc-nd/3.0/us/>

© 2011 Mathematics Teaching and Learning to Teach • School of Education • University of Michigan • Ann Arbor, MI 48109 • mtlt@umich.edu