



# Learning to Do Mathematics as a Teacher

Deborah Loewenberg Ball

University of Michigan School of Education • Ann Arbor, MI

National Council of Supervisors of Mathematics

San Diego, CA • April 21, 2010

SCHOOL OF EDUCATION **M** UNIVERSITY OF MICHIGAN



This work is licensed under the Creative Commons Attribution-NonCommercial-No Derivative Works  
Version 3.0 United States License: <http://creativecommons.org/licenses/by-nc-nd/3.0/us/>

© 2010 Mathematics Teaching and Learning to Teach • School of Education • University of Michigan • Ann Arbor, MI 48109 • [mtlt@umich.edu](mailto:mtlt@umich.edu)

# A problem in teaching

You ask your fourth graders to explain what a rectangle is. One child offers a definition:

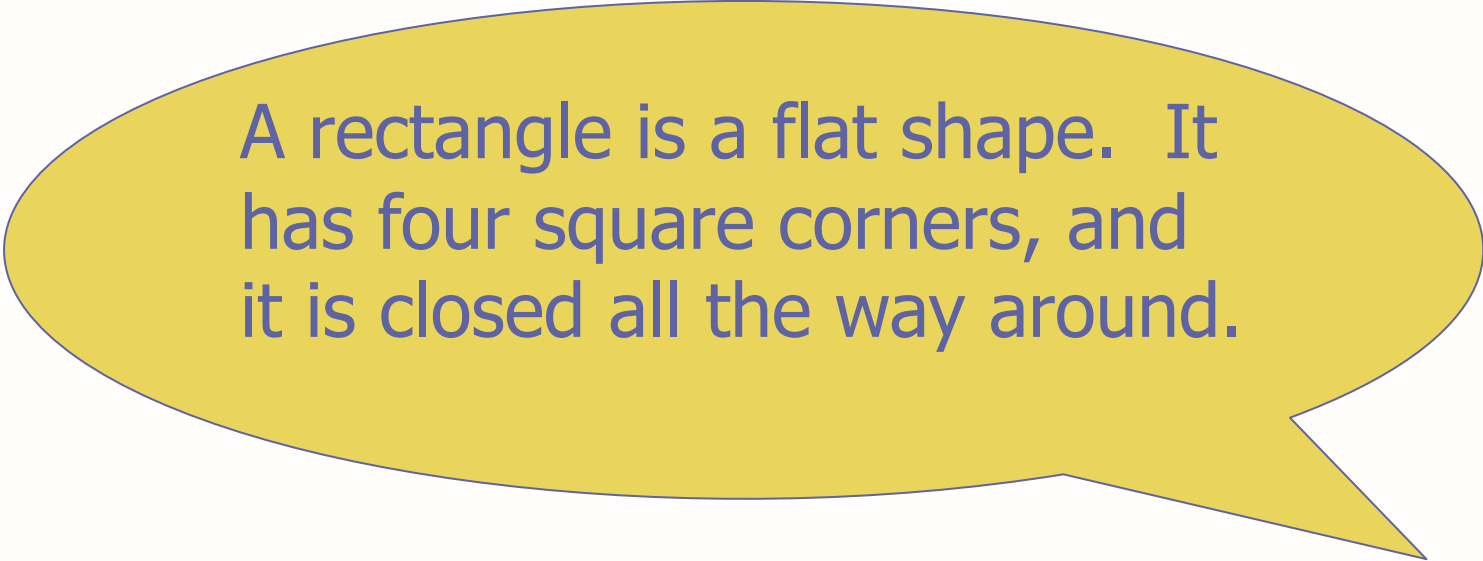

A rectangle is a flat shape. It has four square corners, and it is closed all the way around.

# What is the work for the teacher?

A rectangle is a flat shape. It has four square corners, and it is closed all the way around.

1. To see that something is missing
2. Decide what to do or say
3. Offer a counterexample

What is a shape that satisfies this definition and yet is not a rectangle?

# What is the work for the teacher?

1. To see that something is missing
2. Decide what to do or say
3. Offer a counterexample

“Is this a rectangle?”

(straight sides)



(exactly four square corners)

A rectangle is a flat shape with **straight sides that are connected at exactly** four square corners. It is closed all the way around.

# Teaching involves special kinds of mathematical work

1. Solving special kinds of mathematical problems
2. Engaging in specialized mathematical reasoning
3. Using mathematical language precisely but accessibly

# Choosing pedagogically-strategic examples

Which of the following lists would be best for assessing whether your students understand decimal ordering?  
Justify your choice.

- |    |     |      |      |      |
|----|-----|------|------|------|
| A. | .5  | 7    | .01  | 11.4 |
| B. | .60 | 2.53 | 3.12 | .45  |
| C. | .6  | 4.25 | .565 | 2.5  |

# Analyzing — and “talking” — representations

Which of these can be used to represent  $\frac{5}{6} \div \frac{1}{3}$ ? Explain with reference to all parts of the expression.

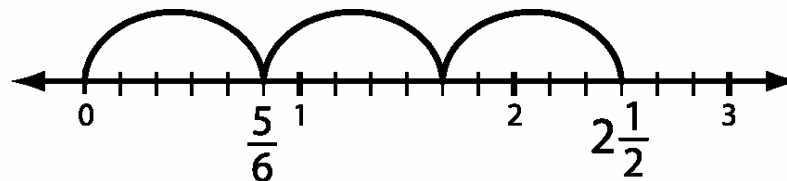
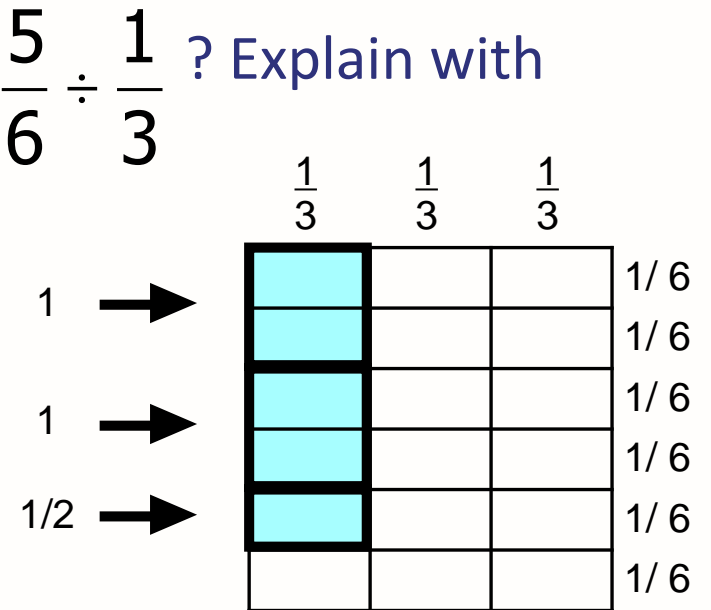
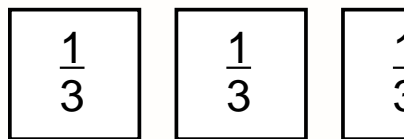
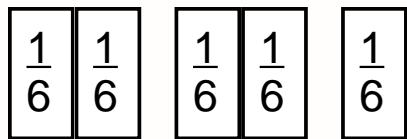
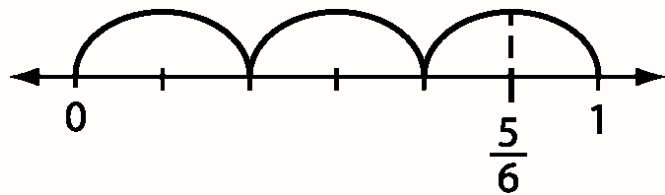

# Analyzing errors

What mathematical steps could have produced this answer?

(a)

$$\begin{array}{r} 49 \\ \times 25 \\ \hline 405 \\ 108 \\ \hline 1485 \end{array}$$

(b)

$$\begin{array}{r} 49 \\ \times 25 \\ \hline 225 \\ 100 \\ \hline 325 \end{array}$$

(c)

$$\begin{array}{r} 49 \\ \times 25 \\ \hline 1250 \\ 25 \\ \hline 1275 \end{array}$$

# Analyzing non-standard (but correct) responses

Which student is using a method that could be used to multiply any two whole numbers?

Student A	Student B	Student C
$\begin{array}{r} 35 \\ \times 25 \\ \hline 125 \\ +75 \\ \hline 875 \end{array}$	$\begin{array}{r} 35 \\ \times 25 \\ \hline 175 \\ +700 \\ \hline 875 \end{array}$	$\begin{array}{r} 35 \\ \times 25 \\ \hline 25 \\ 150 \\ 100 \\ +600 \\ \hline 875 \end{array}$

# Using language precisely and accessibly #1

A polygon is a simple closed plane curve composed of finitely many straight line segments.

## OUR DEFINITIONS

Polygon:

# Using language precisely and accessibly #2

- a) An even number is a number that can be divided into two equal parts.
- b) An even number is any multiple of 2.
- c) An even number is any integer multiple of 2.
- d) An even number is any number whose unit digit is 0, 2, 4, 6, or 8.
- e) A whole number is even if it is the sum of a whole number with itself.

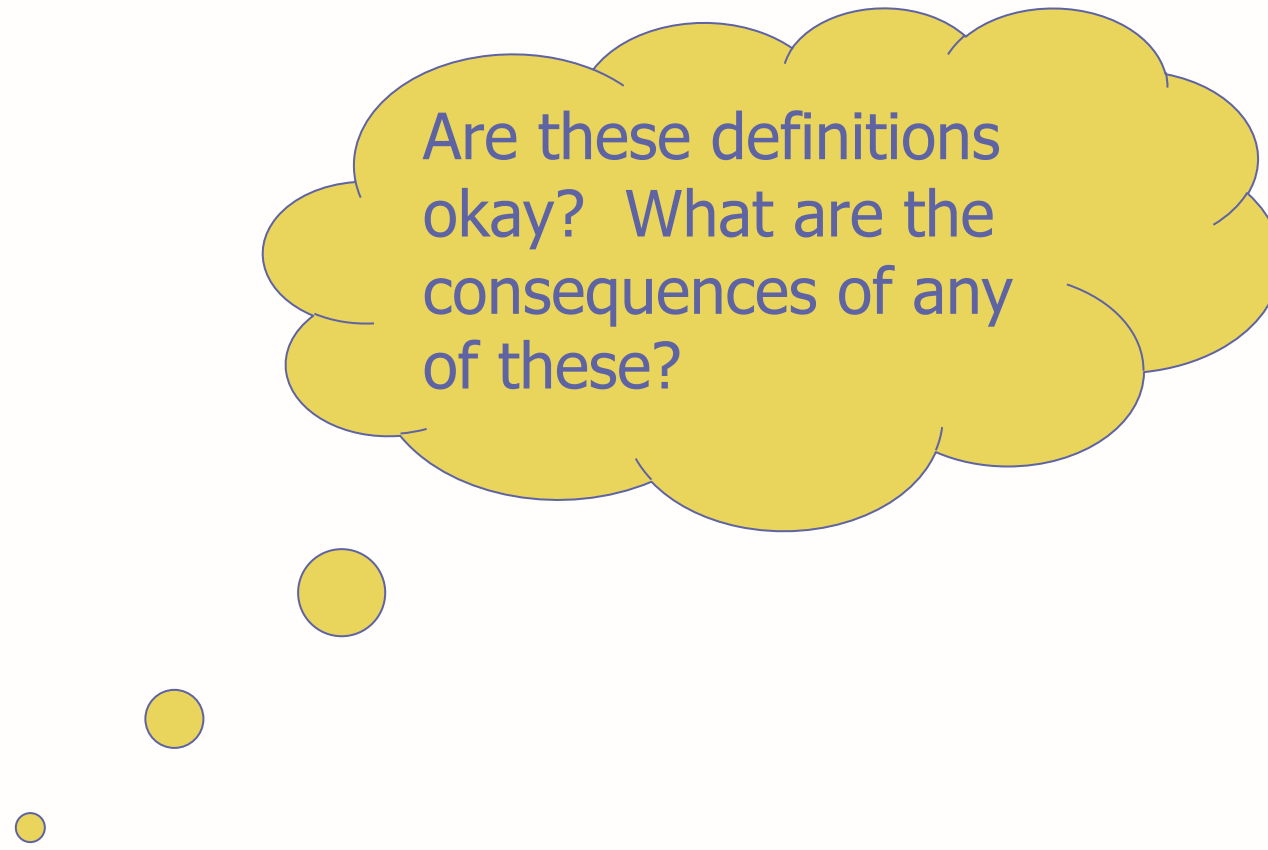

Are these definitions okay? What are the consequences of any of these?

a) An even number is a number that can be divided into two equal parts.

b) An even number is any multiple of 2.

**All numbers, for example 7,  $3/5$ ,  $\sqrt{2}$ ,  $\pi$ , are even!**

c) An even number is any integer multiple of 2.

**This is a correct definition of even number.**

d) An even number is any number whose unit digit is 0, 2, 4, 6, or 8.

**In this case, 36.7 is an even number!**

e) A whole number is even if it is the sum of a whole number with itself.

**This is a correct definition of evenness for whole numbers, and is consistent with the general definition for integers that will arrive later.**

# Posing mathematics problems

## POSSIBLE PROBLEM:

I have pennies, nickels, and dimes in my pocket. If I pull out two coins, what amounts of money might I have?

# Reasoning about different wording

How does the exact wording of the problem affect the mathematical work for my students? Which best fits my goals for them?

# Reasoning about different wording

1. I have pennies, nickels, and dimes in my pocket. If I pull out two coins, what amount of money might I have?
2. I have pennies, nickels, and dimes in my pocket. If I pull out two coins, how many combinations are possible?
3. I have pennies, nickels, and dimes in my pocket. If I pull out two coins, how many different amounts of money are possible? Prove that you have found all the amounts that are possible.

# Reasoning about starting points and sequencing

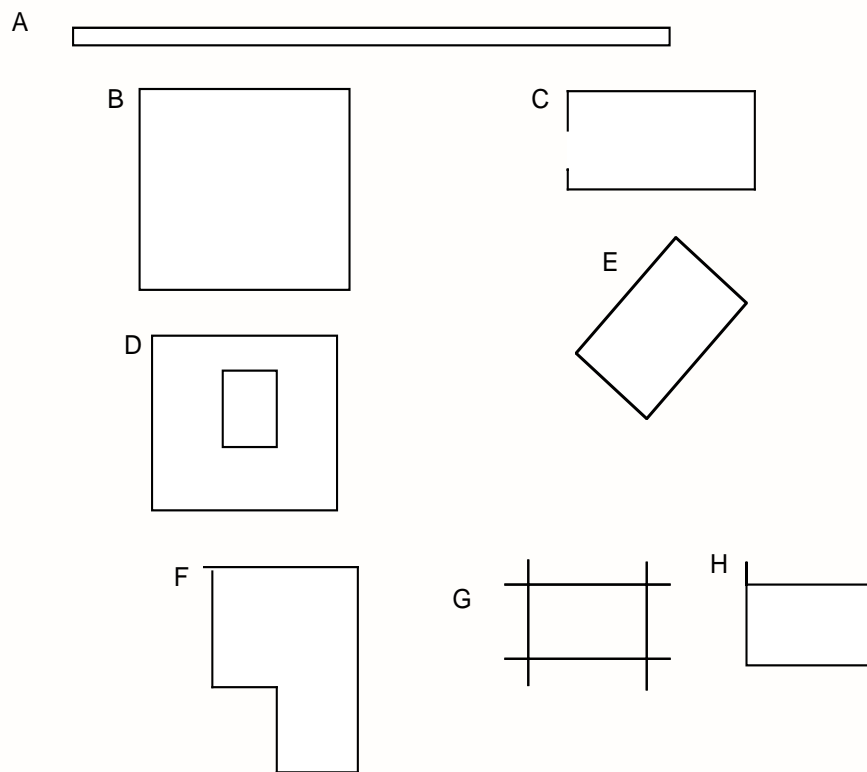

- In a whole-class discussion aimed at developing the concept and definition for “rectangle,” which figure would be good to discuss first? Why?
- How would you sequence these figures to develop the concept and definition of rectangle? Why?

# Teaching involves special kinds of mathematical work

1. Solving special kinds of mathematical problems
2. Engaging in specialized mathematical reasoning
3. Using mathematical language precisely but accessibly

# 1. Solving special kinds of mathematical problems

- Selecting or constructing a strategic example, representation, or task
- Analyzing representations, definitions, non-standard correct responses, incorrect responses
- Developing and using appropriate language

## 2. Engaging in specialized mathematical reasoning

- Comparing mathematical alternatives
- Justifying choices of representations, language, tasks
- Reasoning about starting points and sequences

# 3. Using mathematical language precisely but accessibly

- Coordinating between mathematical details and precision and terms children know or can learn to use
- Coordinating between simple, invented, or everyday language and mathematical details
- Judging what can be left more casual and what not

# What makes this *special* mathematical work?

1. It is performed in the service of helping others learn mathematics.
2. Its warrants are tied both to pedagogical purpose and mathematical integrity.

**What mathematical resources are needed to engage in these special kinds of mathematical work?**



# Mathematical Knowledge for Teaching (MKT)

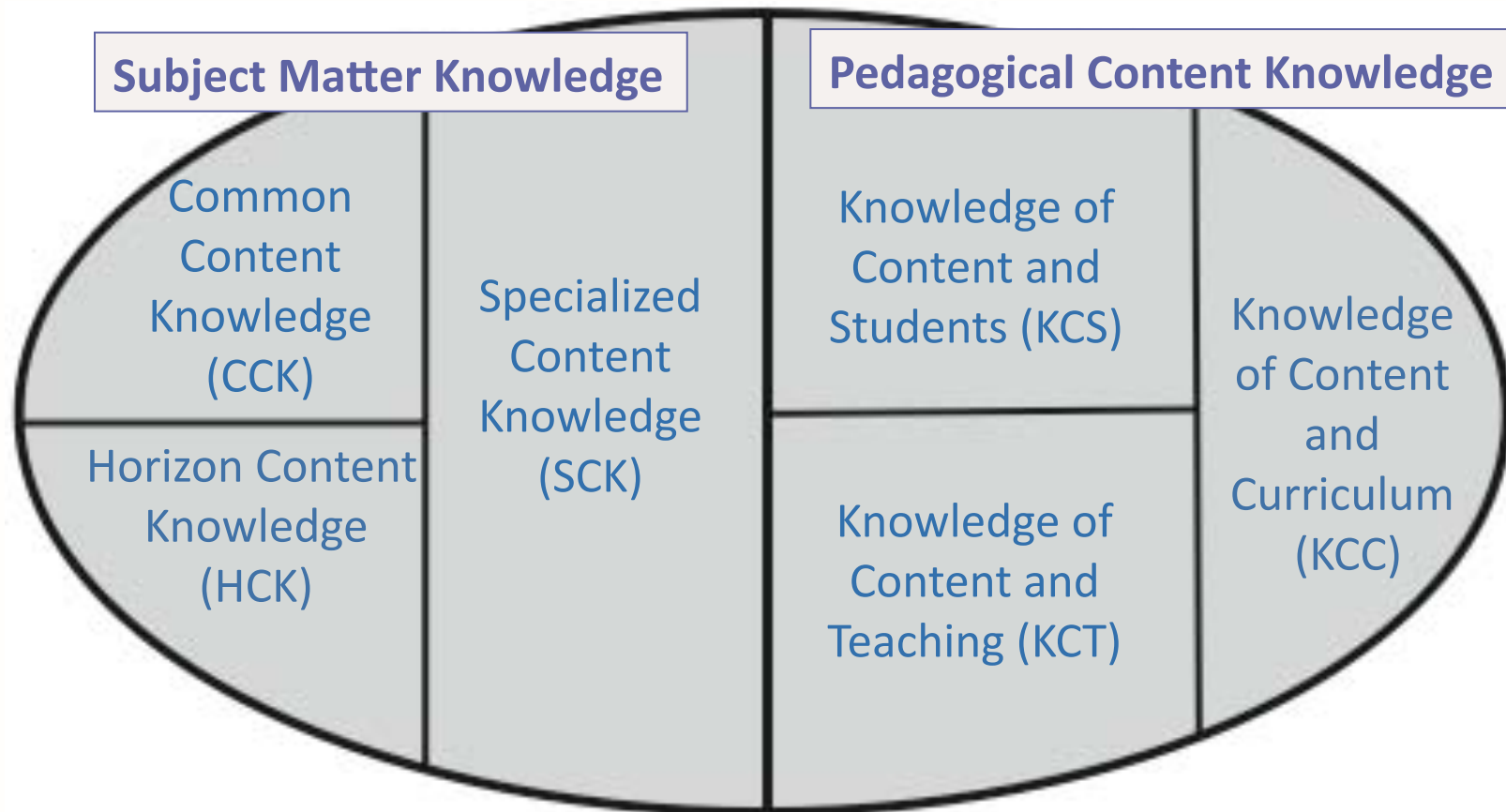

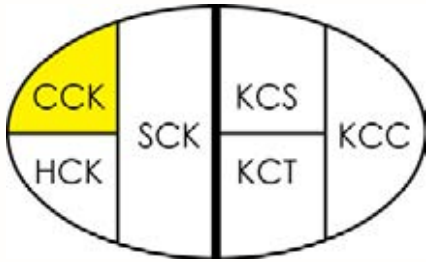

# Common content knowledge (CCK)

Draw a rectangle.



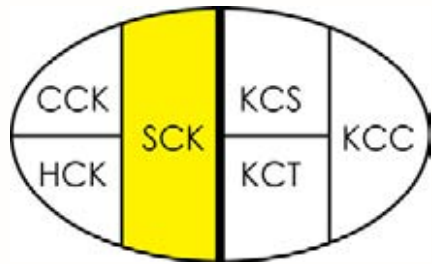

# Specialized content knowledge (SCK)

Which of these figures would be good to present to assess whether students understand what a rectangle is, and why?

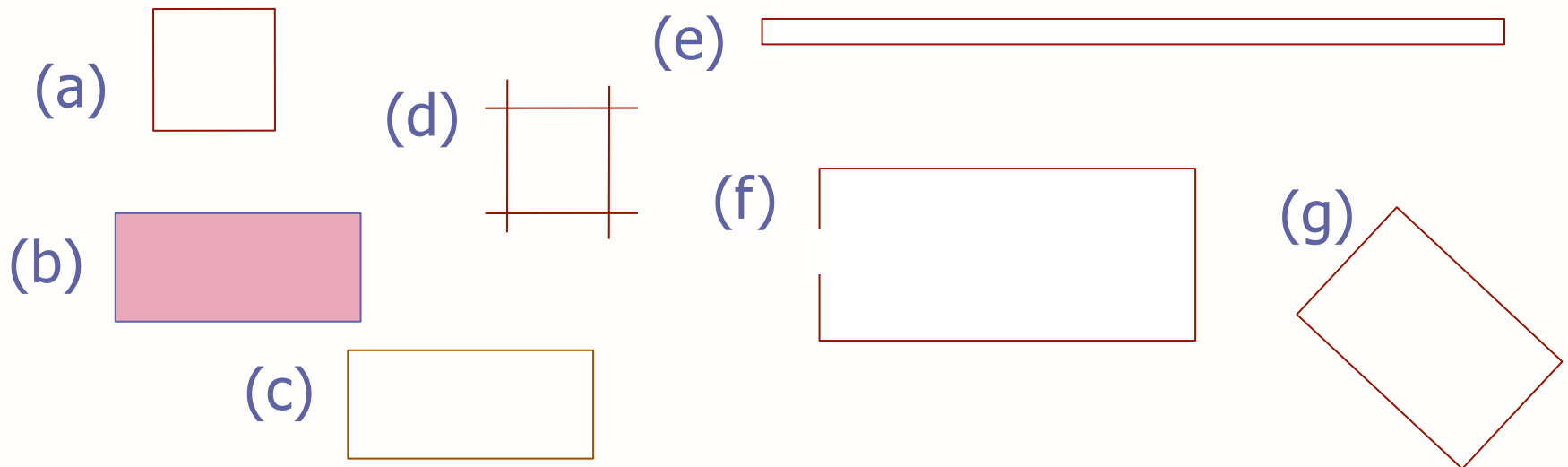

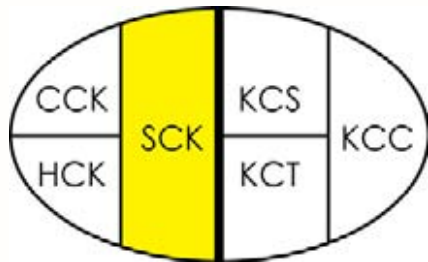

# Specialized content knowledge (SCK)

Which of these is a mathematically accurate definition of “rectangle”?

- ① A rectangle is a figure with four straight sides, two long and two shorter.
- ② A rectangle is a shape with exactly four connected straight line segments meeting at right angles.
- ③ A rectangle is flat, and has four straight line segments, four square corners, and it is closed all the way around.

For any that are not mathematically accurate, give an example that shows what is wrong.

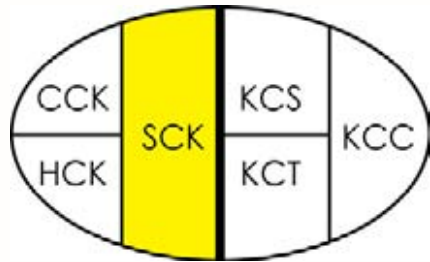

# Specialized content knowledge (SCK)

- ① A rectangle is a figure with four straight sides, two long and two shorter.
- ② A rectangle is a shape with exactly four connected straight line segments meeting at right angles.
- ③ A rectangle is flat, and has four straight line segments, four square corners, and it is closed all the way around.

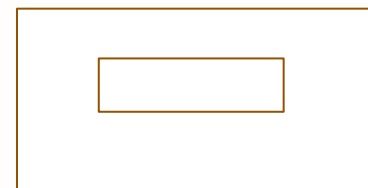

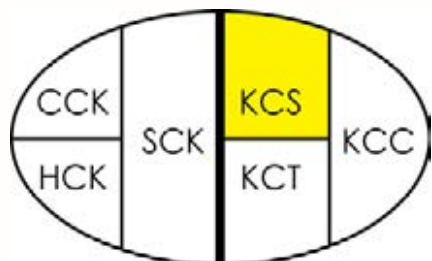

# Knowledge of content and students (KCS)

- Write a mathematically accurate definition of “rectangle” that is usable by second graders.
- How can the notion of “simple closed curve” be expressed in a way that is both mathematically accurate and usable? Which part of this phrase is most challenging for children?

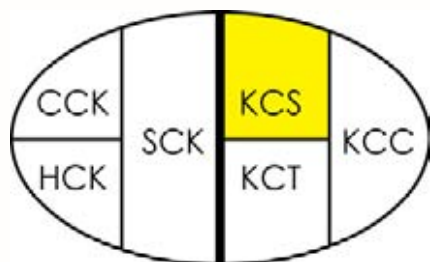

# Knowledge of content and students (KCS)

- What are students likely to know about what a rectangle is?
- What do students typically have difficulty with in learning about rectangles, and why?

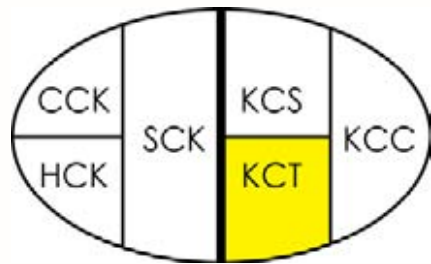

# Knowledge of teaching and content (KCT)

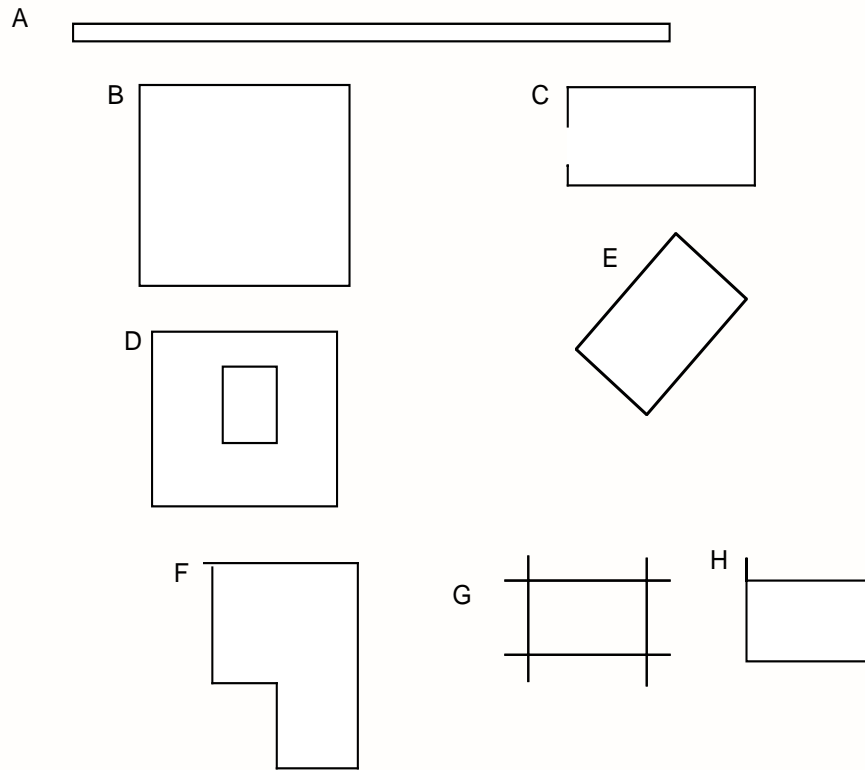

- How would you sequence these figures to discuss the concept of a rectangle?
- What task would you create using these figures (or others) to set up a productive discussion aimed at developing a definition?
- In a whole-class discussion, which one would be good to discuss first?

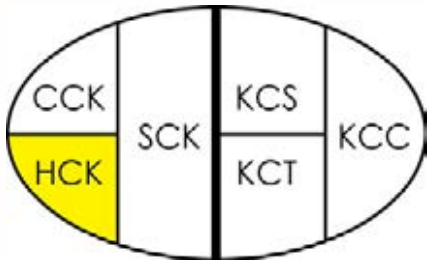

# Horizon content knowledge (HCK)

- Is it okay to shade in the figures shown to students – e.g., 
- What are the issues involved with the fact that children learn about rectangles before polygons?

# A challenge for teachers — and teacher educators

Teaching is a practice.

It is the *use of mathematics in practice*  
that matters.

# How can teachers learn to do the specialized mathematical work of teaching?

1. Unpacking mathematics ideas and practices
2. Practicing mathematical work of teaching
3. Developing horizon knowledge

# Unpacking mathematical ideas

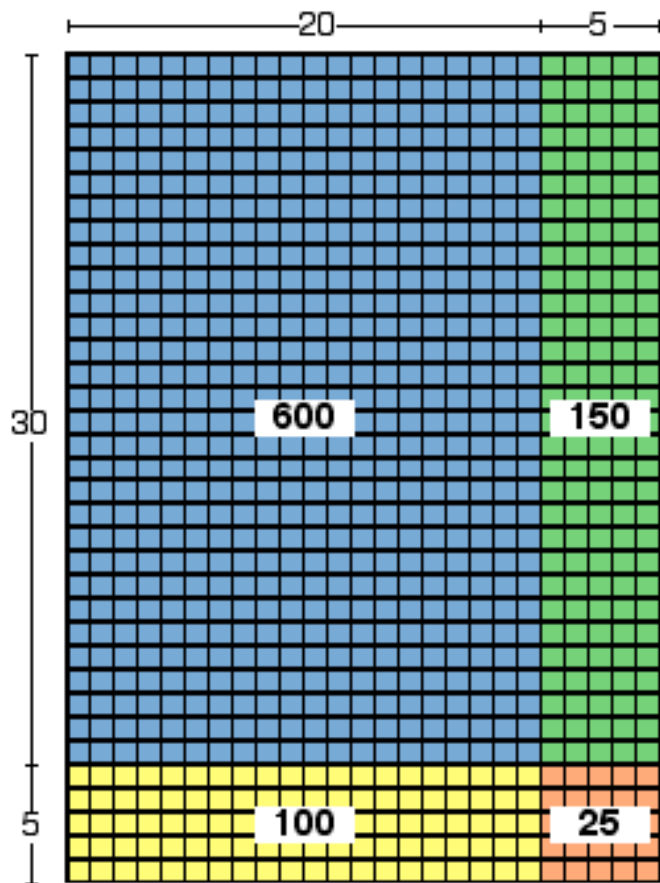

**A**

$$\begin{array}{r} 35 \\ \times 25 \\ \hline 125 \\ + 75 \\ \hline 875 \end{array}$$

**B**

$$\begin{array}{r} 35 \\ \times 25 \\ \hline 175 \\ + 700 \\ \hline 875 \end{array}$$

**C**

$$\begin{array}{r} 35 \\ \times 25 \\ \hline 25 \\ 100 \\ 150 \\ + 600 \\ \hline 875 \end{array}$$

# Developing horizon knowledge

Exploring ideas of density of the rational numbers

Developing awareness of the two kinds of infinity

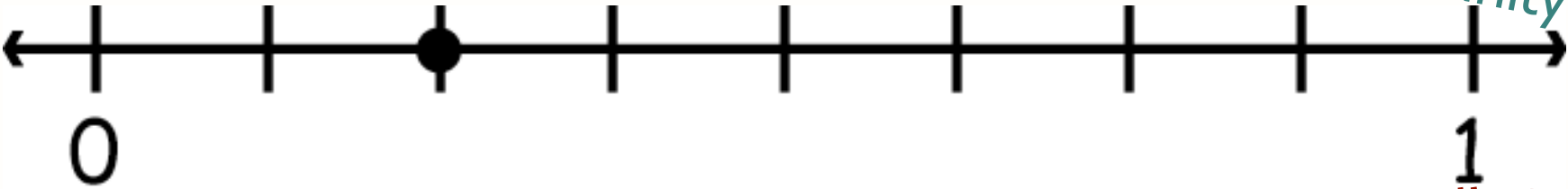

All the numbers of K-8 mathematics "live" on the number line



# Practicing the mathematical work of teaching

- Working on examples like we have done, including practicing providing reasons
- Developing fluency and speed
- Developing sensibilities about mathematical language

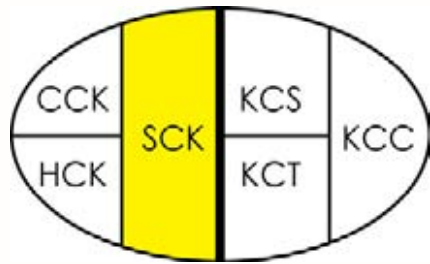

# Practice #1: Representing and mapping across representations

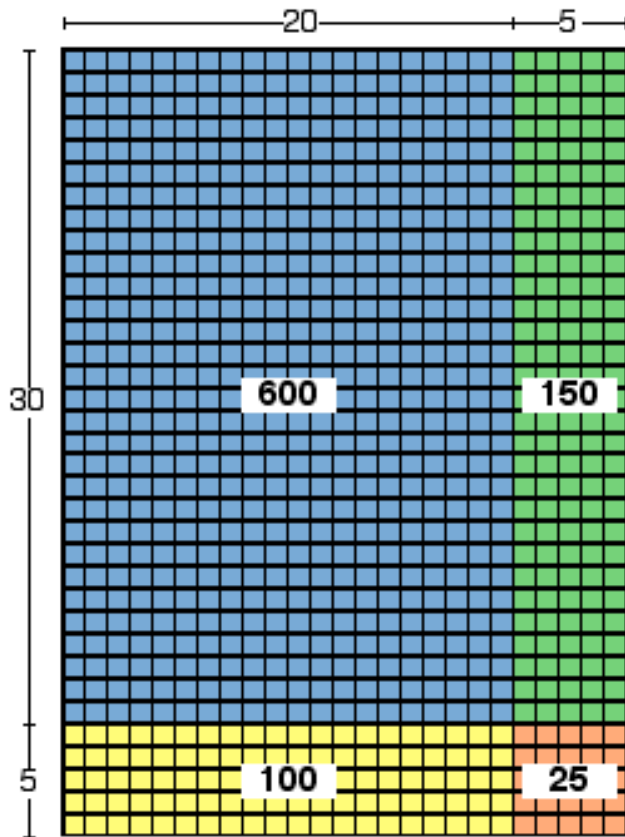

**A**

$$\begin{array}{r} 35 \\ \times 25 \\ \hline 125 \\ + 75 \\ \hline 875 \end{array}$$

**B**

$$\begin{array}{r} 35 \\ \times 25 \\ \hline 175 \\ + 700 \\ \hline 875 \end{array}$$

**C**

$$\begin{array}{r} 35 \\ \times 25 \\ \hline 25 \\ 100 \\ 150 \\ + 600 \\ \hline 875 \end{array}$$

# Practice #2: Becoming mathematically agile on your feet

$$\begin{array}{r} 27 \\ 38 \\ + 19 \\ \hline 74 \end{array}$$

What problem would you pose next to this pupil, and why?

# Practice #3: Developing sensibilities about mathematical language

- Use of quantifying terms: e.g., exactly, no more than, no less than, at least, at most
- Attention to the wording of mathematical tasks
- Care with definitions, their role, their requirements, and judgments about when, where, and why they are essential
- Awareness of the overlaps and conflicts between mathematical language and everyday language, other school language, and students' home languages

# Conclusion

1. Teaching involves doing mathematics in some special ways that are connected to the purposes of teaching practice — i.e., helping others learn mathematics.
2. This special kind of work involves special kinds of problems, engaging in special kinds of mathematical reasoning, and using mathematical language in specially careful ways.
3. Teachers need opportunities to develop skills with this special kind of mathematical work.

# Opportunities for mathematics teacher educators

## Dev-TE@M Fall 2010 Pilot Seeking Piloters

### *Representing and Comparing Fractions in Elementary Mathematics Teaching*

- Ten 1.5-hour sessions
- Multimedia materials
- Seminar/webinar format (face-to-face or real-time remote)
- Elementary mathematics

[http://www.umich.edu/  
~devteam/](http://www.umich.edu/~devteam/)

## Mathematical Knowledge for Teaching Teachers

- Elementary Mathematics Laboratory
- July 26-August 6
- Ann Arbor, Michigan
- Instructor: Hyman Bass

[http://sitemaker.umich.edu/  
eml2010](http://sitemaker.umich.edu/eml2010)

**THANK YOU!**  
Slides will be available  
at Deborah Ball's website  
  
(Google "Deborah Ball")

